

# ShopBot®



## **Invision Enclosure for Desktop Max Assembly and Use Guide**

# Table of Contents

1. [Introduction to Assembly Methods](#) (3-14)
2. [Top Frame Assembly](#) (15-60)
3. [Base Frame Assembly](#) (61-71)
4. [Door Installation](#) (72-83)
5. [Window Installation](#) (84-95)
6. [Additional Features](#) (96-100)



## Introduction to Assembly Methods

3

The frame of your enclosure is constructed from extruded, anodized V-slot Aluminum—sometimes just called “extrusion”. Extrusion is frequently used for frames that need to be rigid, but quick to assemble and modify.

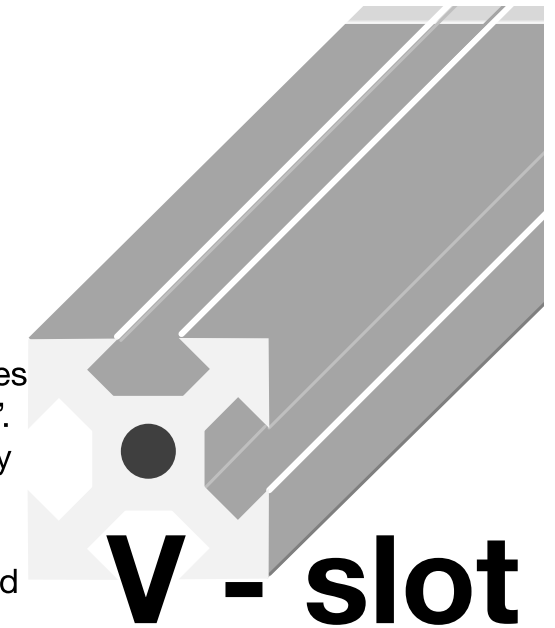

4 The phrase V-slot refers to the shape of the slots that result from the design of the die used when extruding the aluminum. They can be used as attachment points for plates or even other pieces of extrusion. Certain types of screws can be inserted directly into the V-slot where the screws' threads will engage the sharp edge of the slot and hold tight.

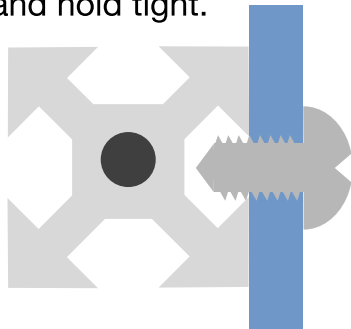

5

The assembly of this enclosure will make use of many joints of this type.

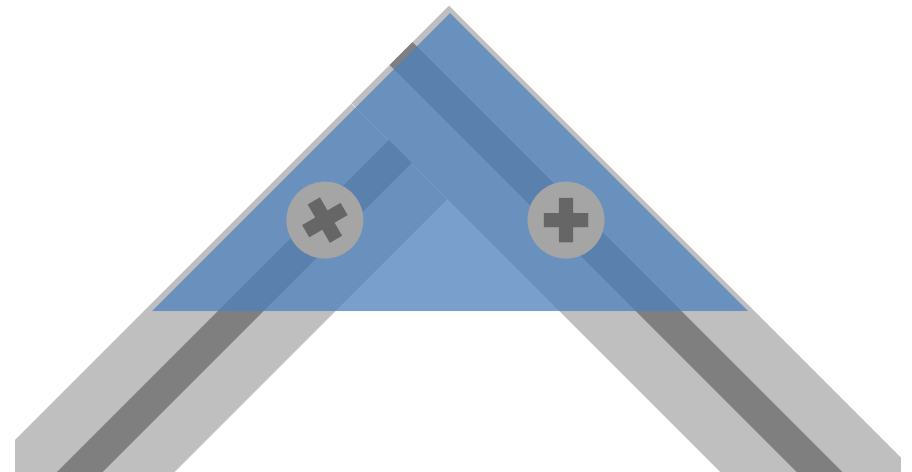

- 6 To make assembly even easier-we've manufactured our own ShopBot-cut joinery for V-slot extrusion. They will be referred to by the letter of the alphabet that they most closely resemble.

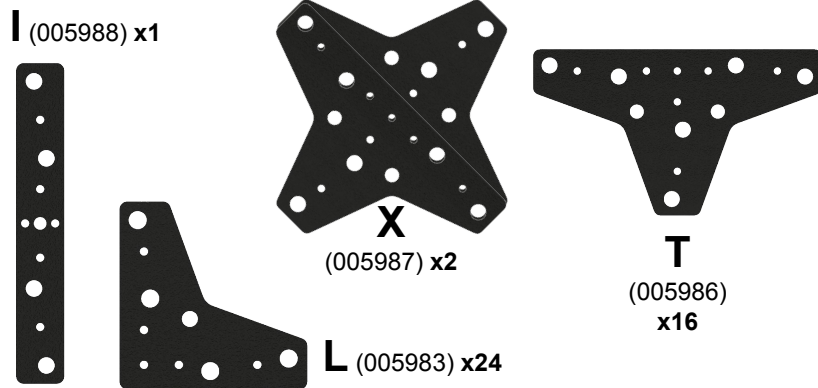

- 7 You'll just need to drop the joint into place on the extrusion and tighten the bolt-heads to lock the structure in place.

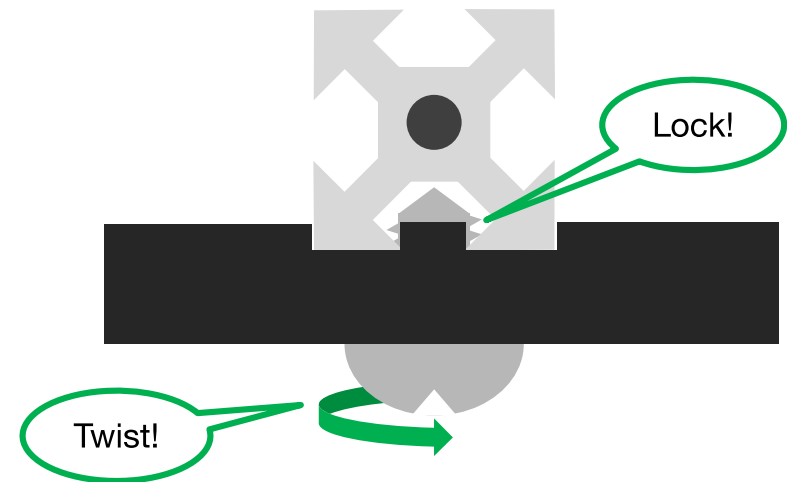

- 8 Most of the joints have protruding "stops" to ensure accurate positioning during assembly. Just slide the extrusion in until it contacts the corner stop and hold firm while you tighten the bolts.

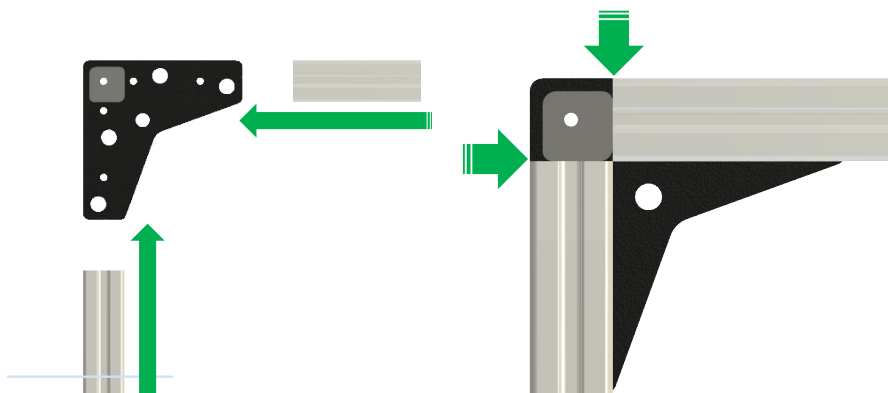

- 9 Every connection will be made with at least two screws. To ensure a tight fit, always tighten the screw furthest from the corner first, this will pull the extrusion into the corner. Once the outer screws are tightened, the extrusion will be fixed in place and the inner screws can be tightened.

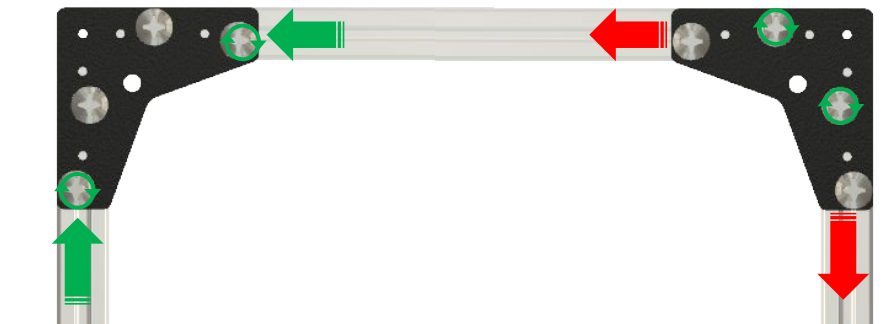



**10** Throughout this guide, we'll use colors and names to refer to each side of the enclosure to help keep you oriented. The "front" of the enclosure will be the side with the doors.

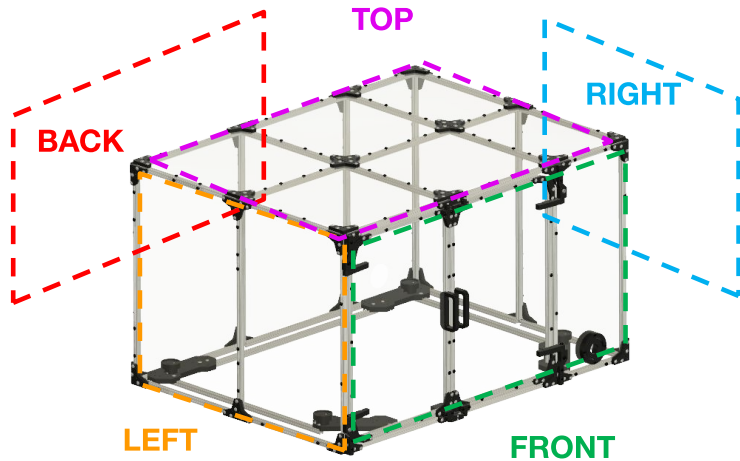

**11** The extrusion for your enclosure is cut to three lengths: 30.5", 19.5" and 12.5"; These lengths will be identified by colors...Yellow, Red and Blue respectively.

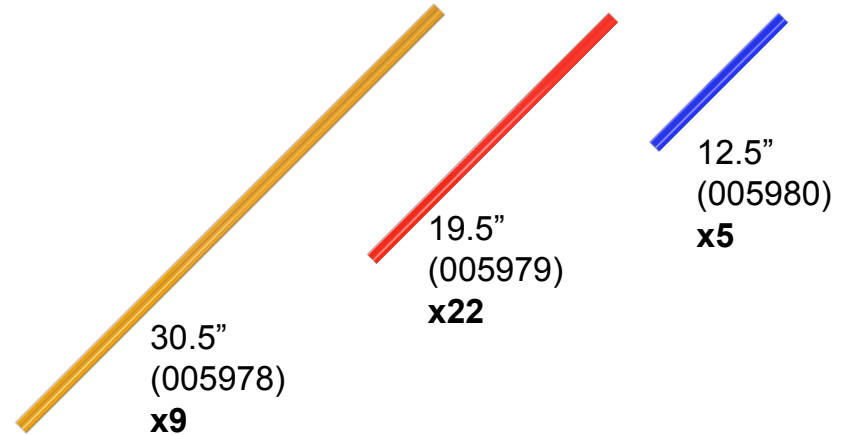

**12** These are the four types of hardware that will be used in the assembly of your enclosure.

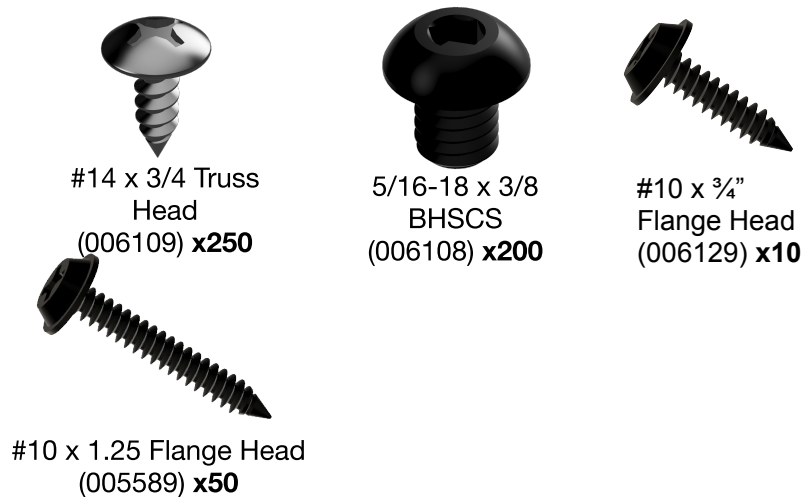

**13** Your assembly kit also includes all of the tools that will be required to assemble your enclosure

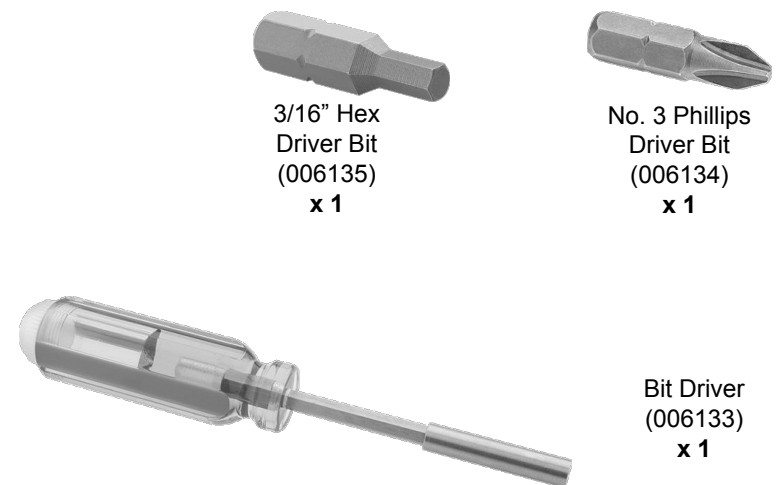



## Enclosure Top Frame Assembly

15

These are the parts that you will need for this section.

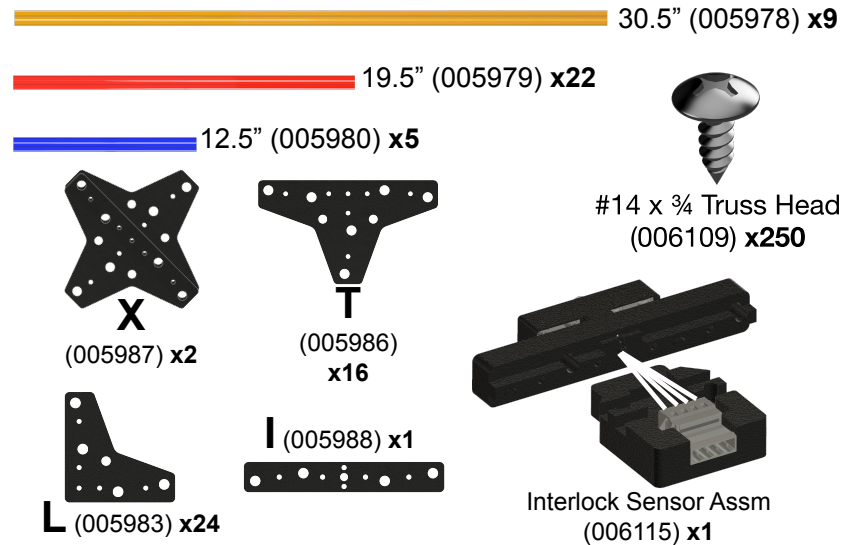

16

This section of the assembly instructions will guide you through the construction of the top of the enclosure.

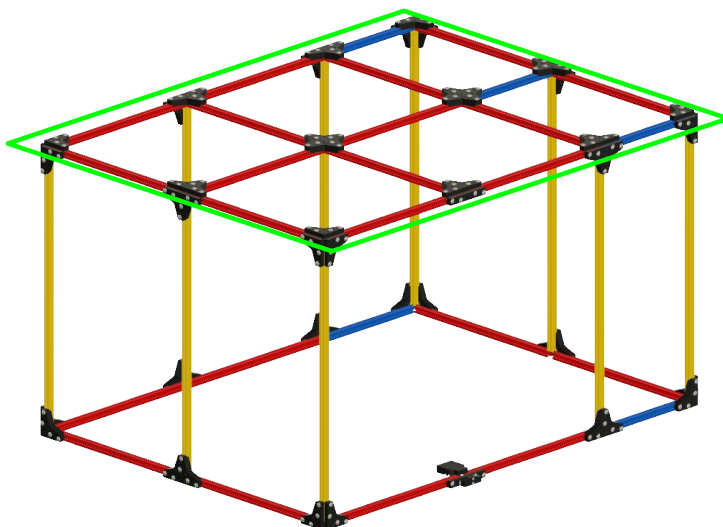

17

The top of the enclosure is constructed of **14x** 19.5" sticks and **3x** 12.5" sticks. Lay them out in an open space according to the arrangement shown in the diagram below.

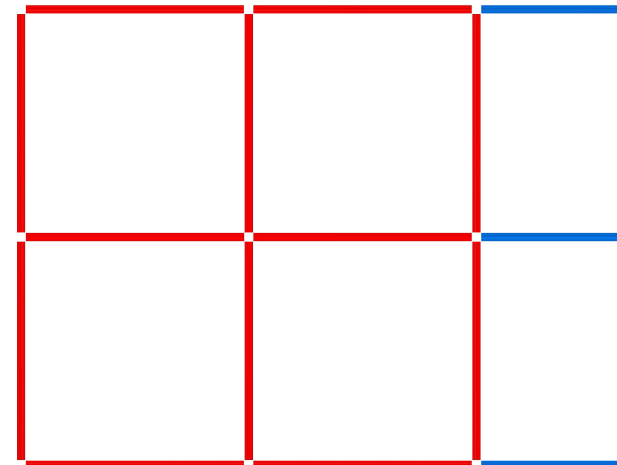

- 18 Insert **2x** X Joints into the center of the enclosure top and fasten in place using the #14 x 3/4" Truss Head Screws.

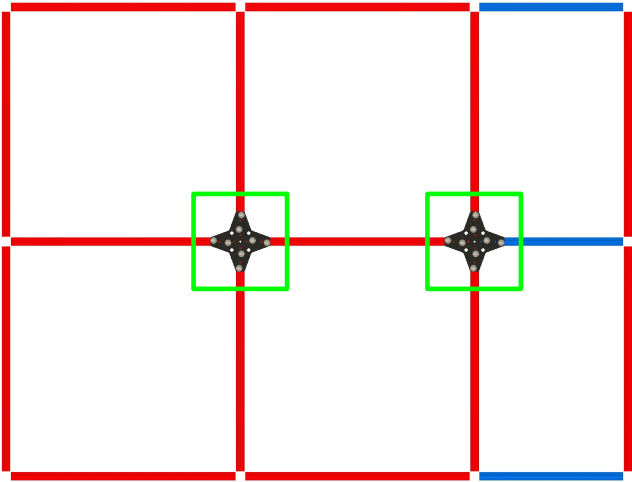

- 19 Insert **6x** T Joints around the perimeter of the enclosure top and fasten in place.

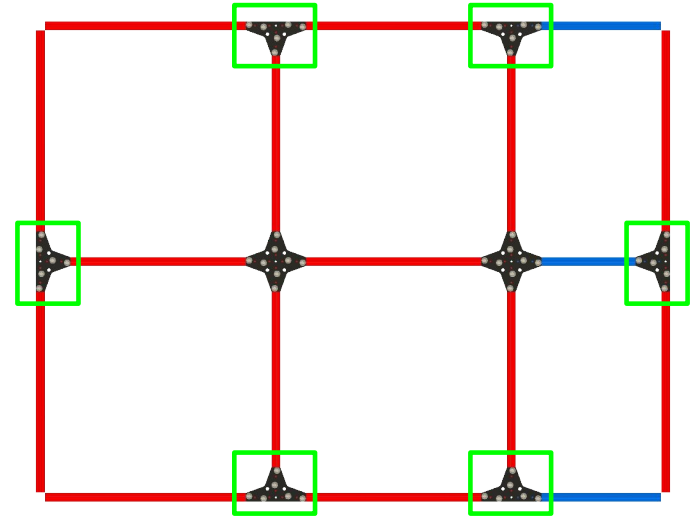

- 20 Insert **4x** L Joints on the corners of the Enclosure Top and fasten in place.

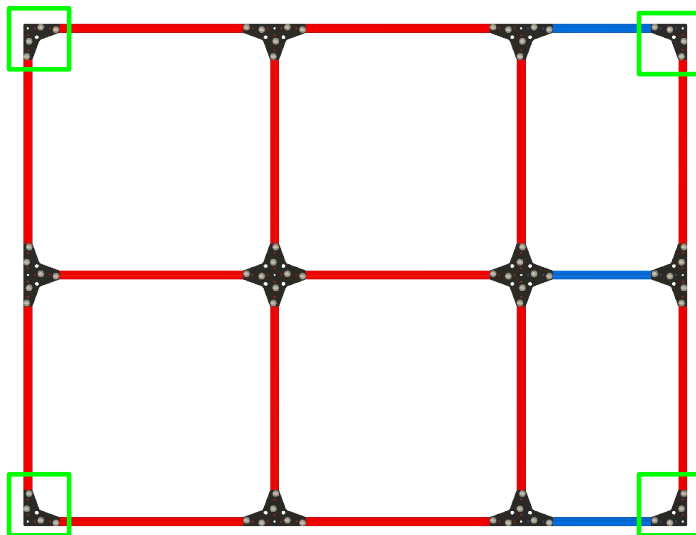

- 21 For the next section, you'll want to flip your assembly over to provide easier access to the area you'll be working on.

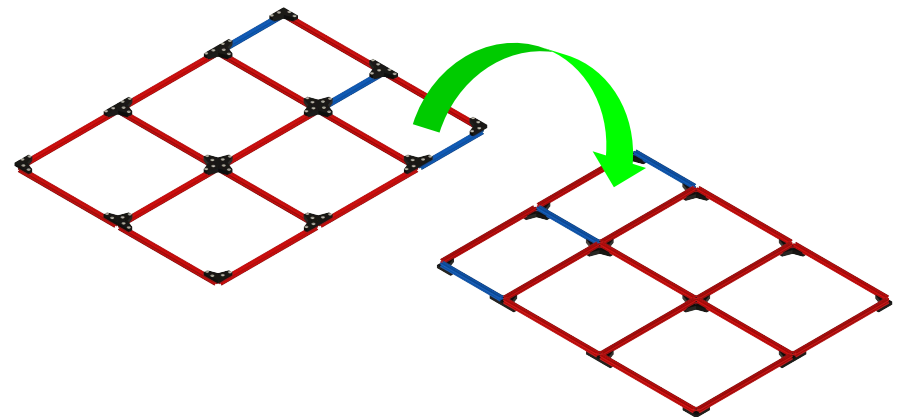

22 Attach two L Joints and a T Joint to the left edge of the enclosure top.

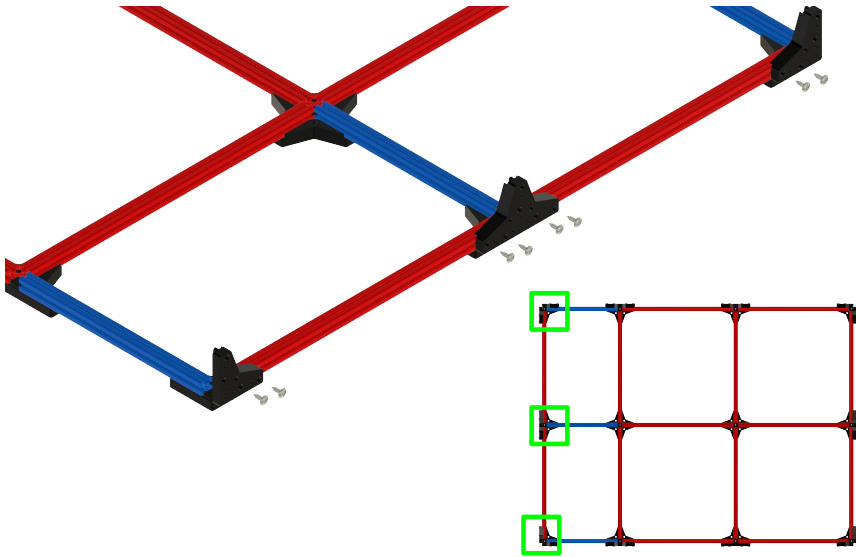

23 Attach an L Joint and a T Joint to the back edge of the enclosure top.

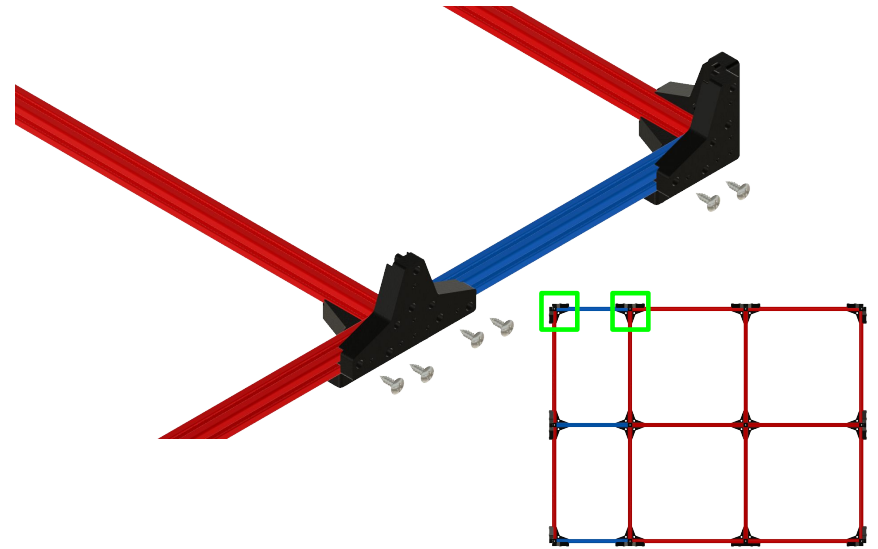

24 Attach an L Joint and a T Joint to the back edge of the enclosure top.

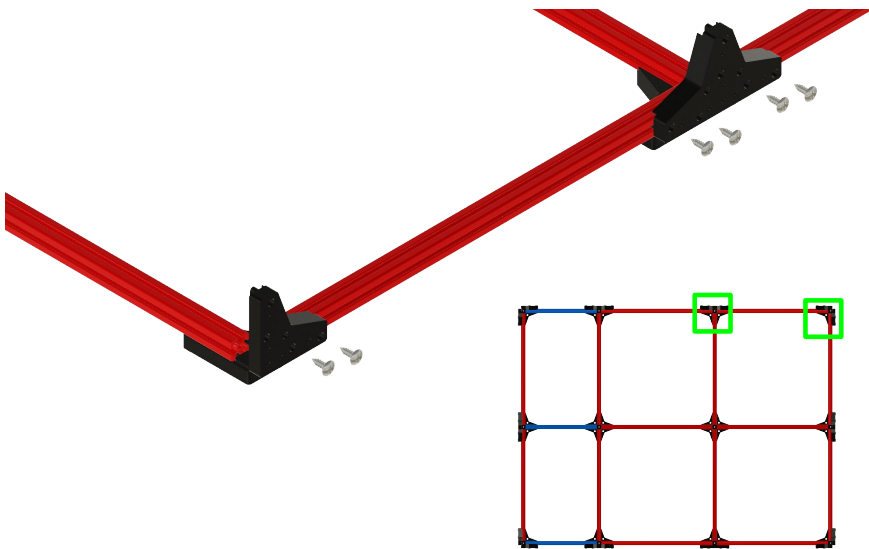

25 Attach two L Joints and a T Joint to the right edge of the enclosure top.

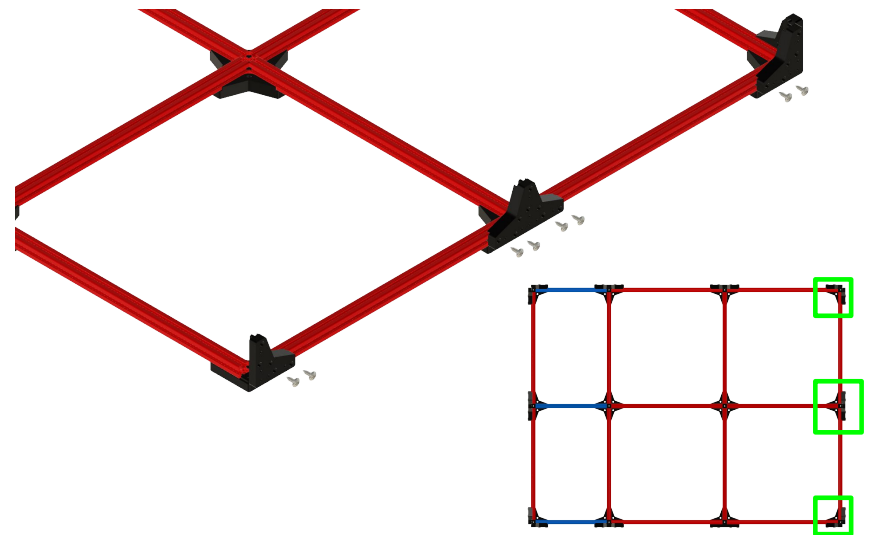

26 Attach an I Joint and an L Joint to the front edge of the enclosure top.

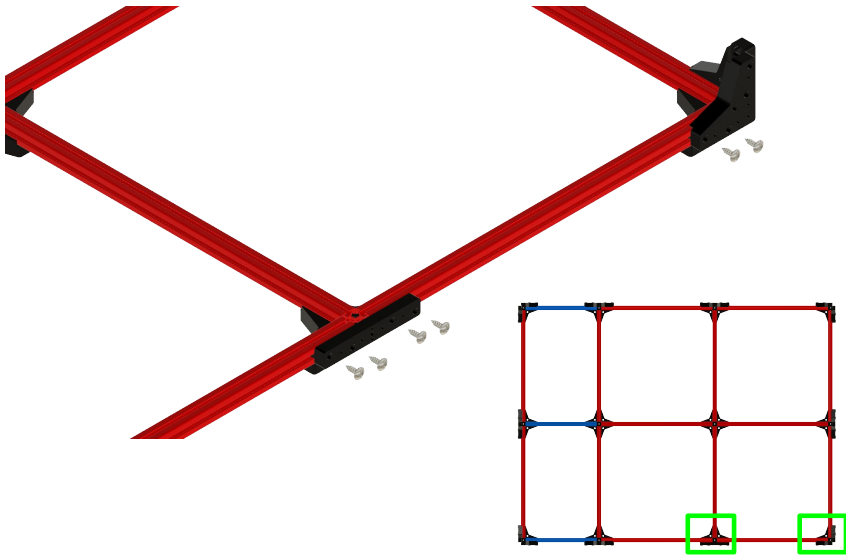

27 Attach an L Joint and a T Joint to the front edge of the enclosure top.

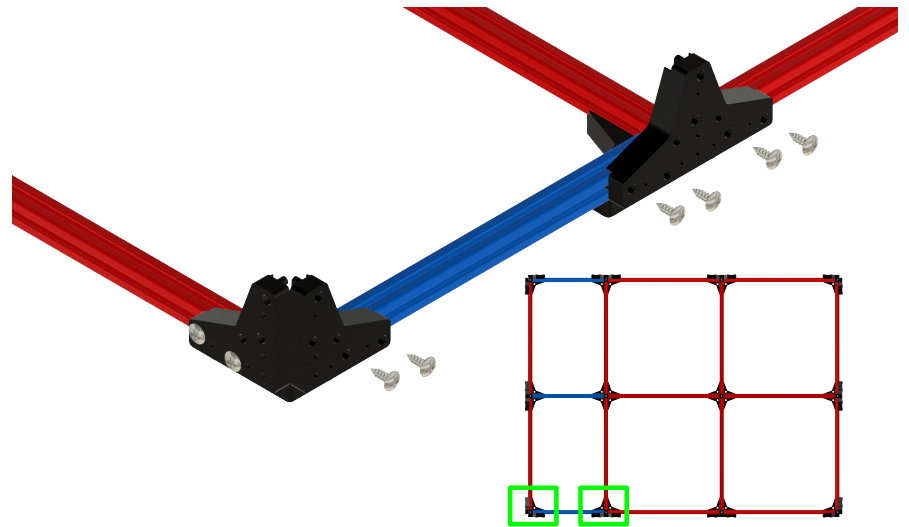

28 Attach 9x 30.5" Sticks to the four corners of the enclosure along with the 5 open slots on T Joints around the frame.

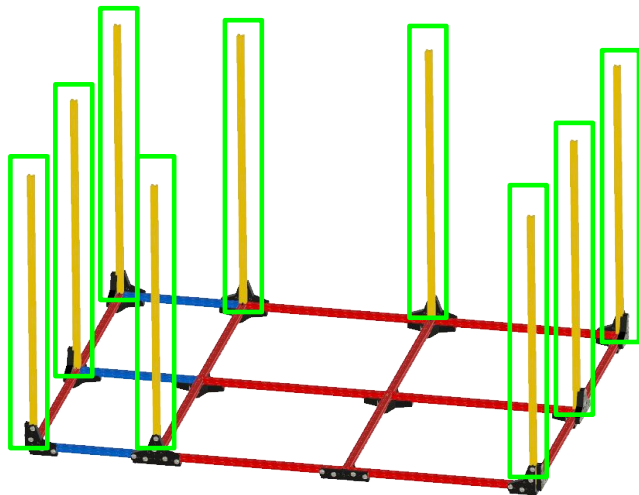

29 For this next it will be easiest to look at the enclosure "right-side-up". You may want to physically flip the enclosure assembly right-side-up at this point as well.

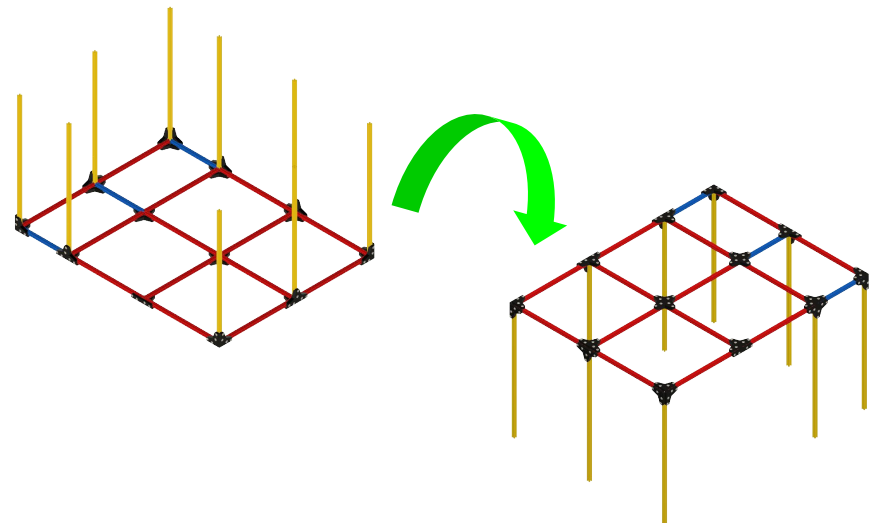

**30** We'll now finish the enclosure frame with more joinery and extrusion around the base of the frame.

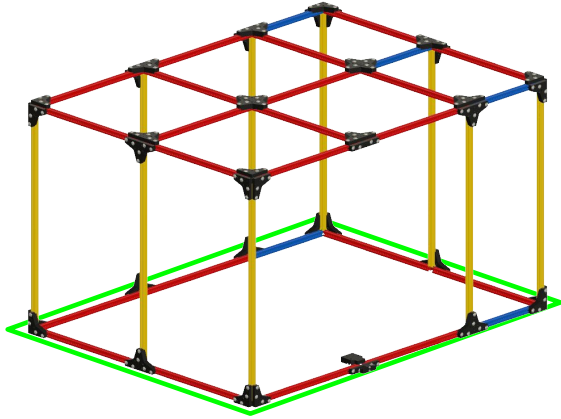

**31** For this section, you will be facing the LEFT of the enclosure.

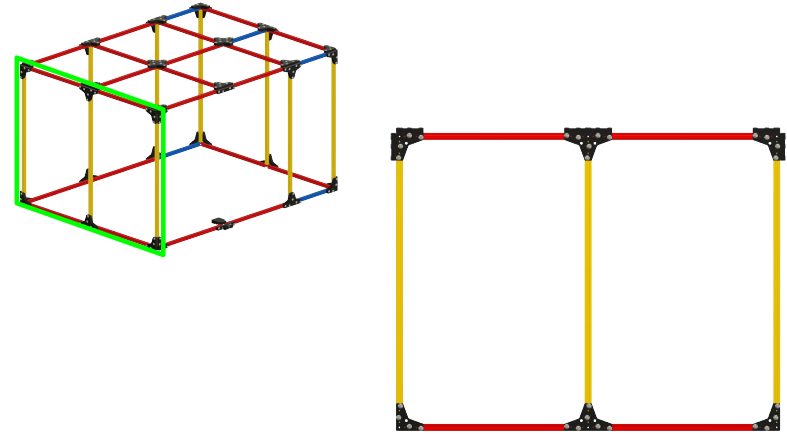

**32** Attach an L Joint to the bottom corner of the enclosure.

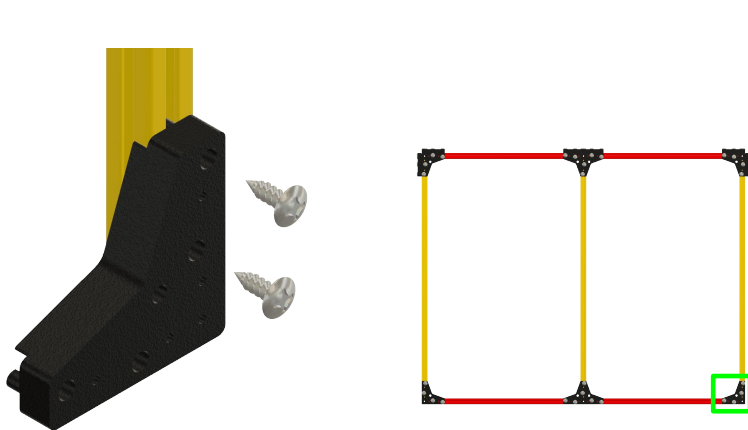

**33** Attach a T Joint to the base of the enclosure.

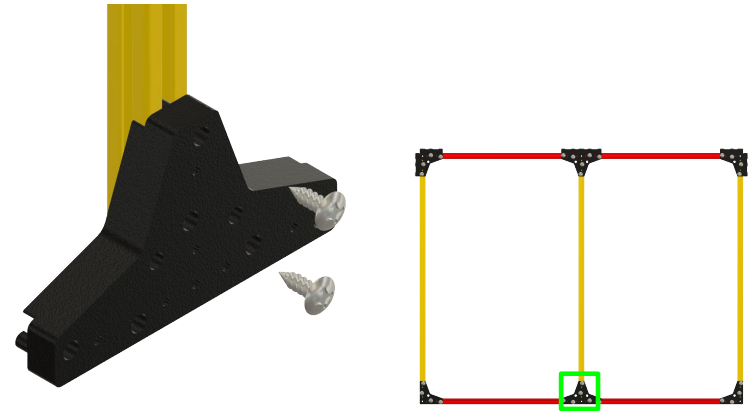

34 Attach an L Joint to the bottom corner of the enclosure.

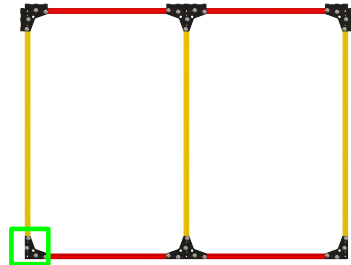
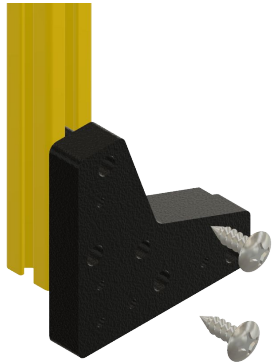

35 Attach 2x 19.5" Sticks to the base of the enclosure frame.

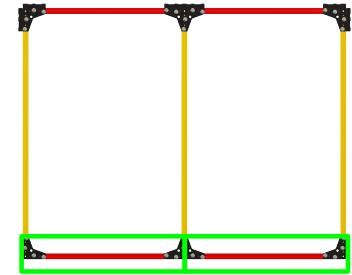
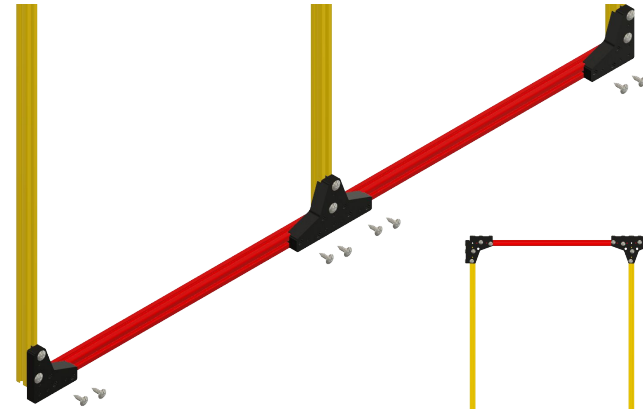

36 For this section, you will be facing the BACK of the enclosure.

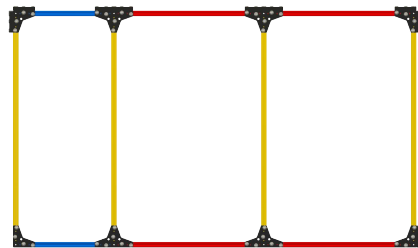
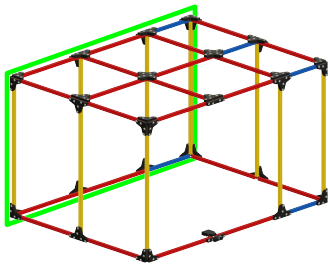

37 Attach an L Joint to the bottom corner of the enclosure.

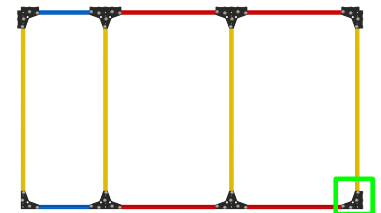
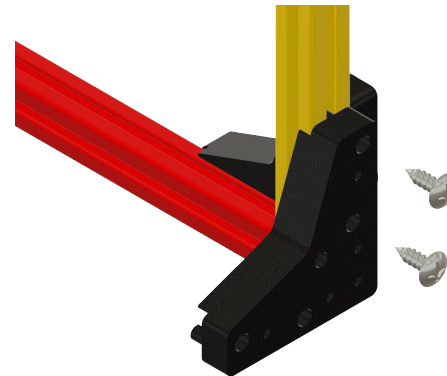

38 Insert a T Joint at the base of the enclosure.

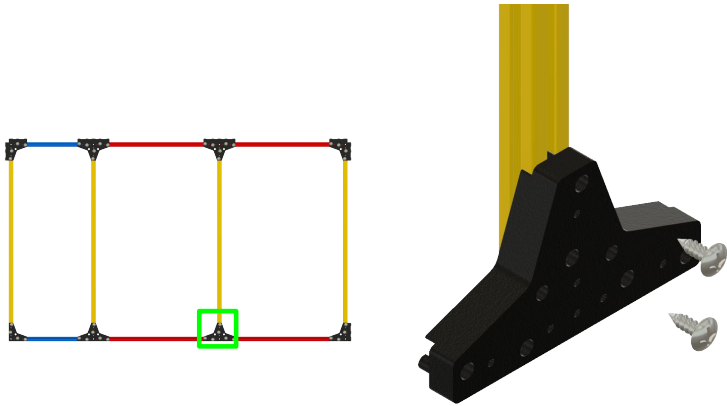

39 Insert another T Joint at the base of the enclosure.

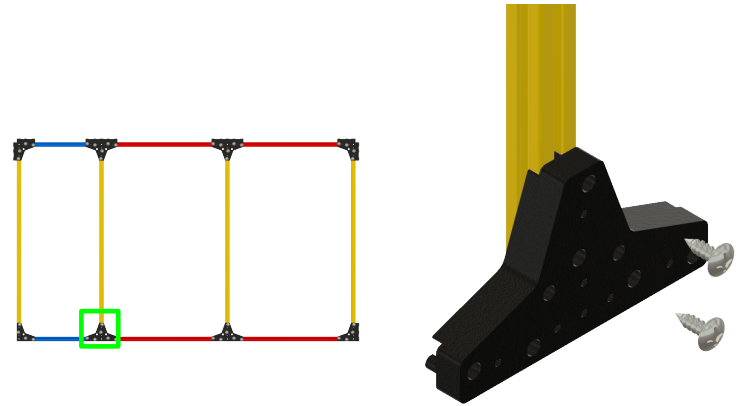

40 Attach 2x 19.5" Sticks to the base of the enclosure frame.

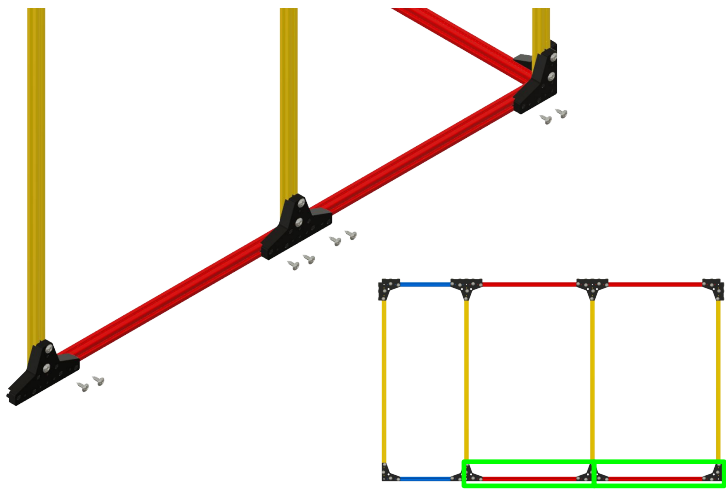

41 Attach an L Joint to the bottom corner of the enclosure.

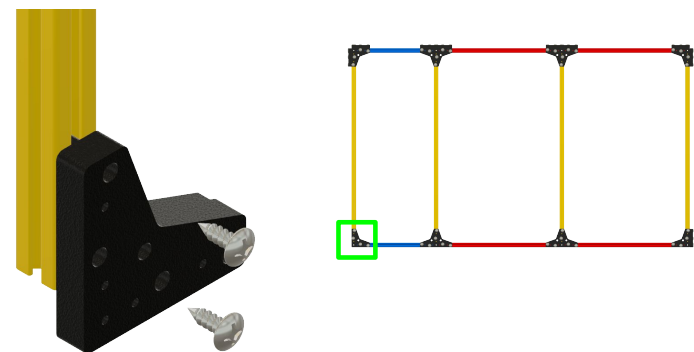



42 This section of the assembly instructions will guide you through the construction of the top of the enclosure.

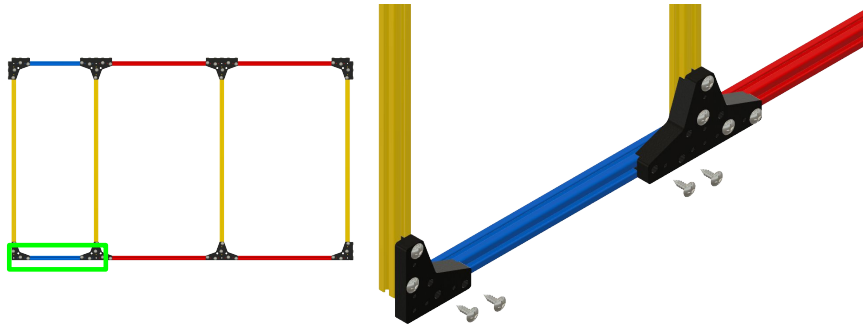

43 For this section, you will be facing the RIGHT of the enclosure.

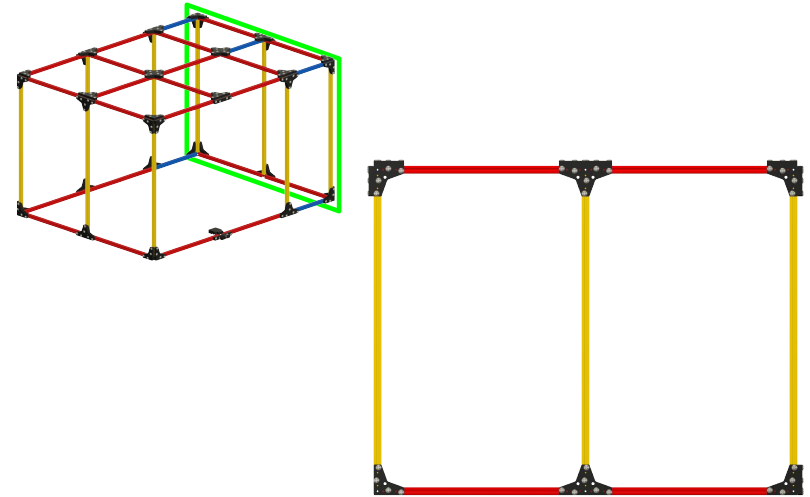

44 Attach an L Joint to the base of the enclosure.

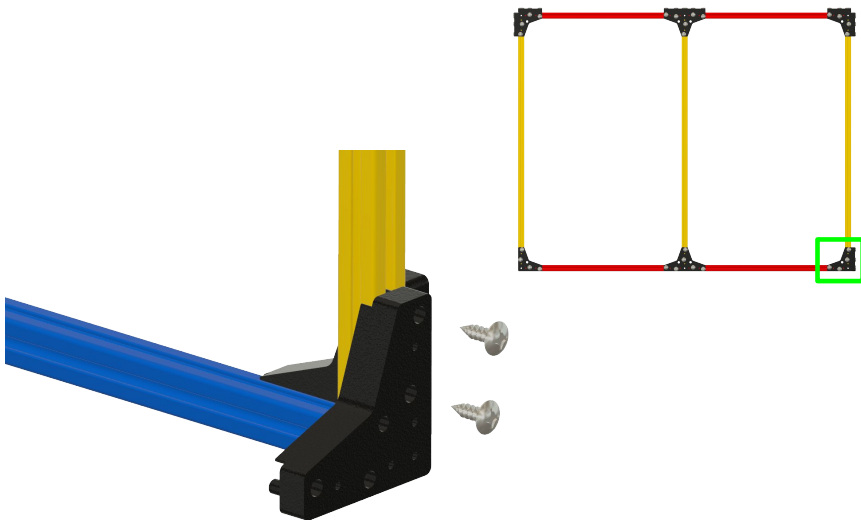

45 Attach a T Joint to the base of the enclosure.

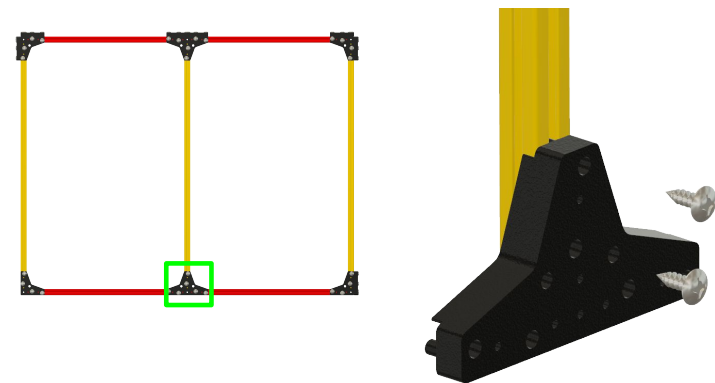

46 Attach an L Joint to the bottom corner of the enclosure.

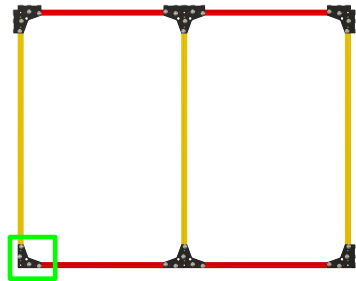
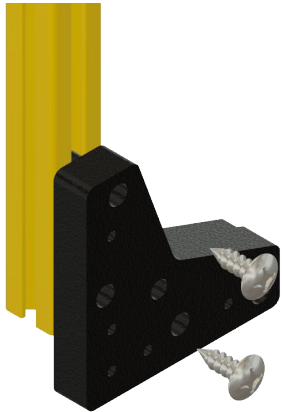

47 Attach 2x 19.5" Sticks to the base of the enclosure frame.

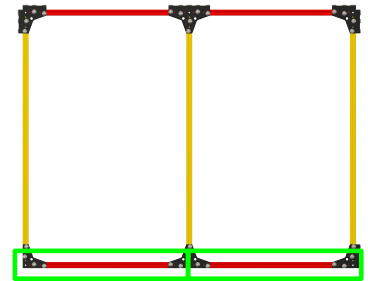
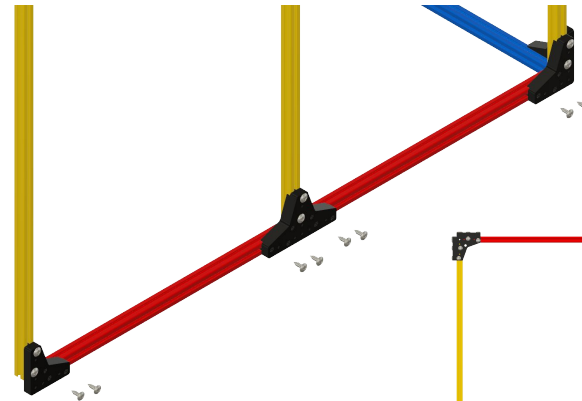

48 For this section, you will be facing the FRONT of the enclosure.

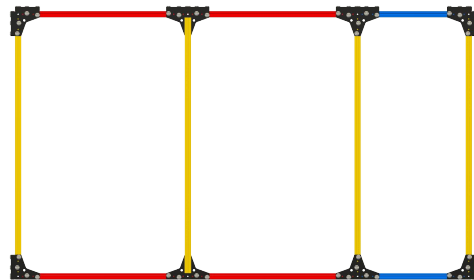
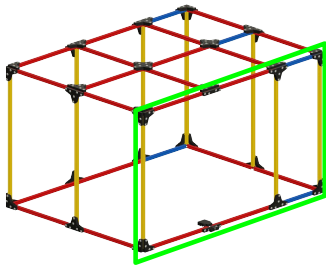

49 Attach an L Joint to the bottom right corner of the enclosure.

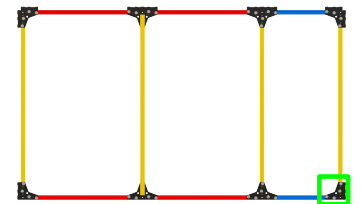
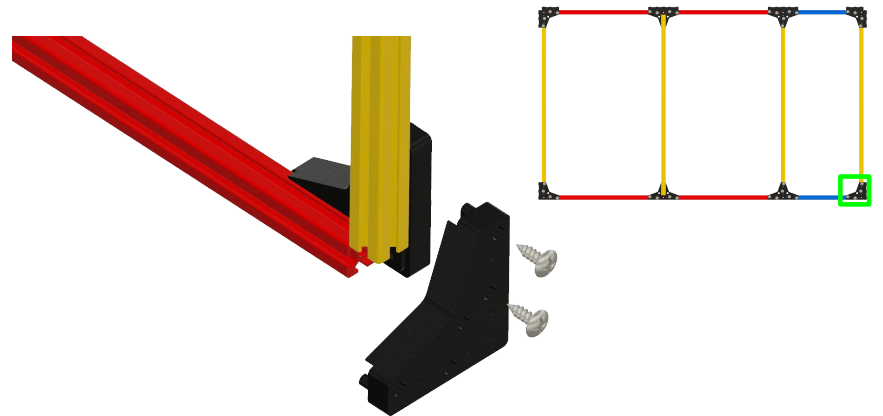

50 Insert a 12.5" Stick at the bottom right of the enclosure--connecting it to the L Joint there.

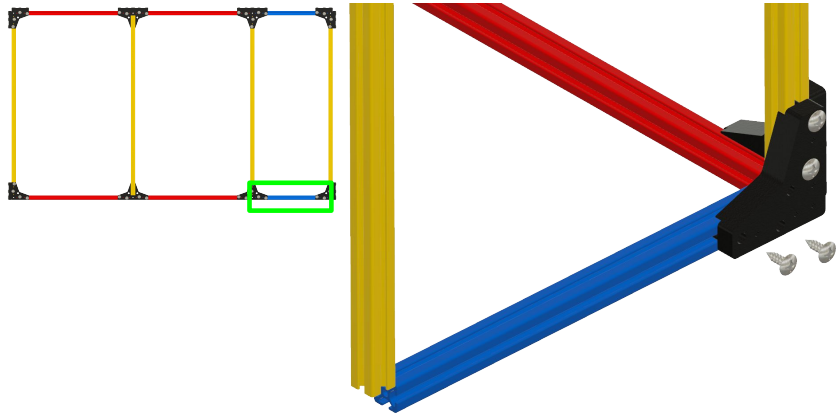

51 Attach a T Joint to the Bottom Edge of the enclosure

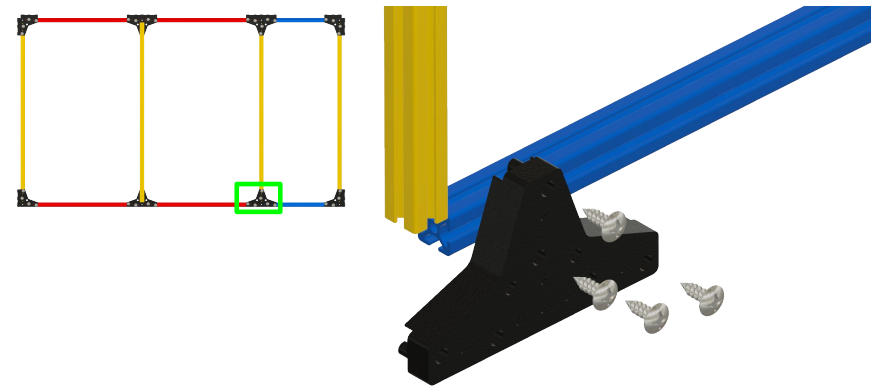

52 Attach an L Joint to the bottom corner of the enclosure.

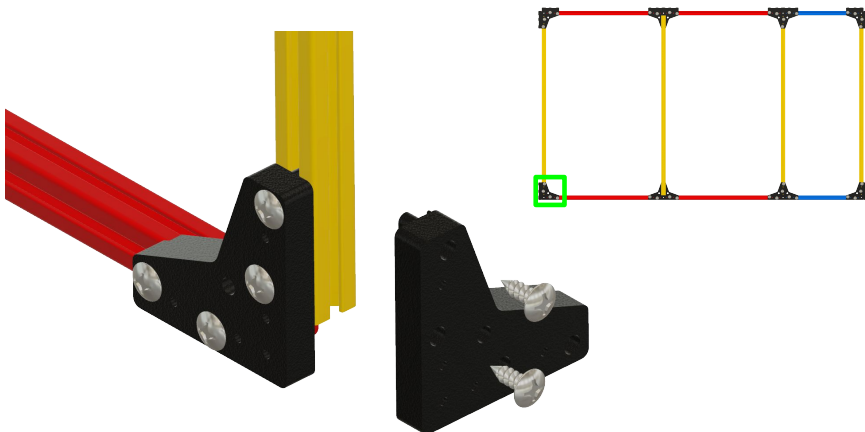

53 Attach 2x 19.5" Sticks to the L and T Joints on the base of the enclosure frame.

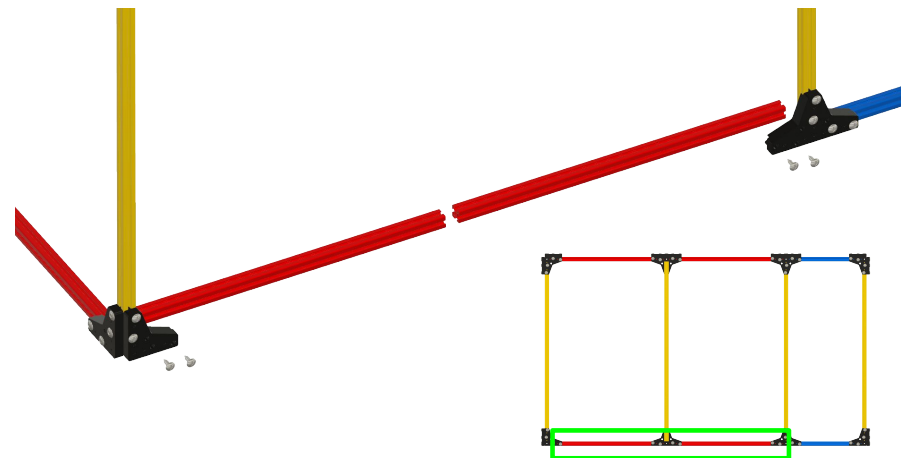

54

In order to attach the I Joint to the enclosure frame, you will need to temporarily remove the sensor module. It is held in place by two #8 x1.25" Screws. Remove these screws and pull the sensor module away from the I Joint. Do not remove the wire connecting the sensor module to the connector housing.

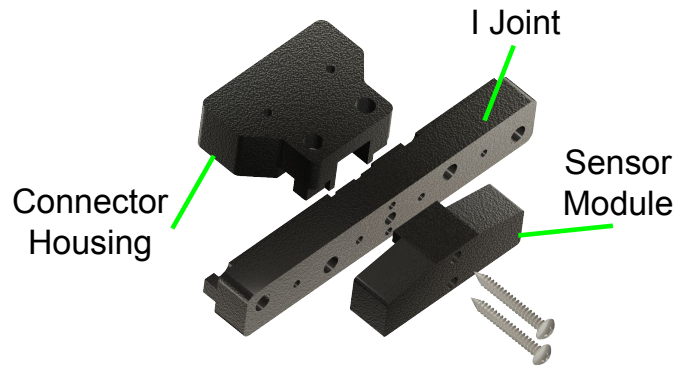

55

Press the I Joint into place along the center base of the enclosure frame and secure in place.

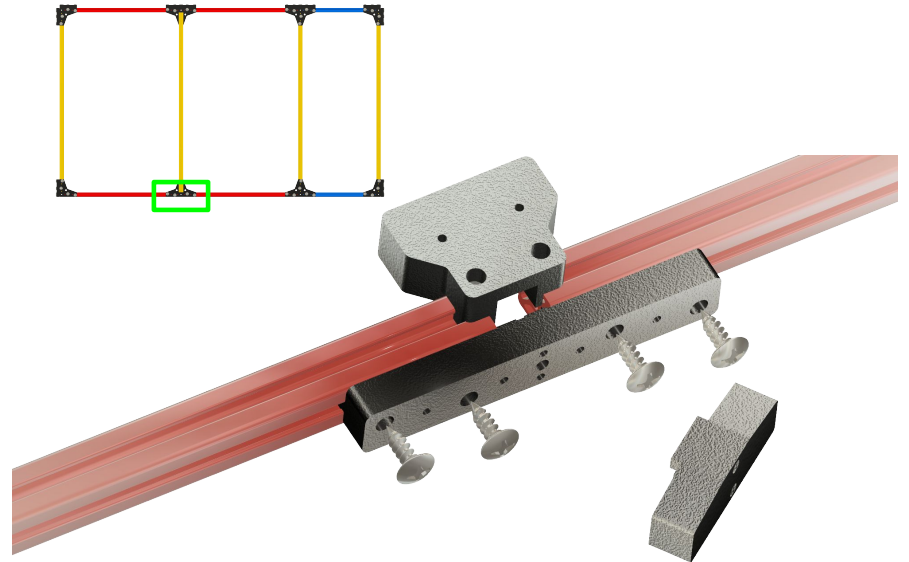

56

Reattach the Sensor Module to the I Joint using the two #8x1.25" Screws. Be sure to pull the wiring through the hole in the I connector as you press the sensor module into place, so that there is plenty of slack on the other side for the connector housing.



57

Now attach the connector holder at the bottom front of the enclosure frame to the front piece of extrusion on the base frame using 2x #14 x 3/4" Truss Head Screws.

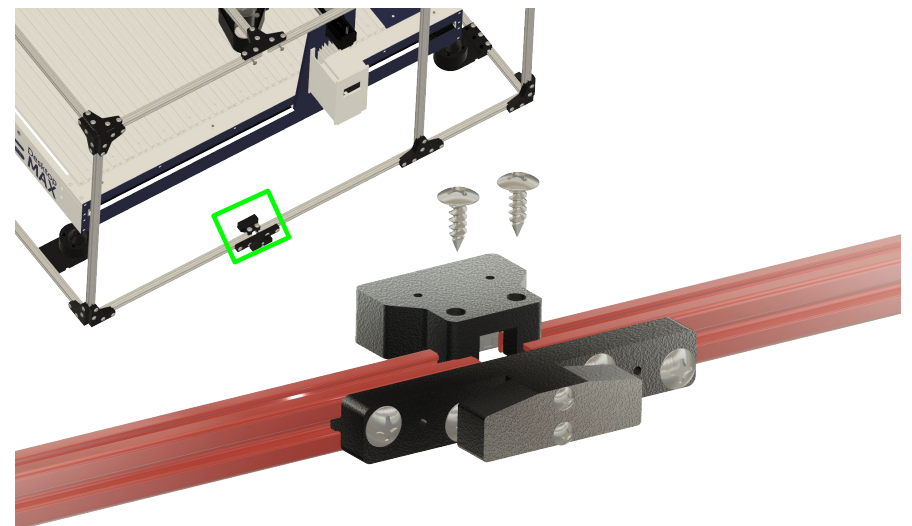

58

Locate the small connector for the safety interlock on the corner of the tool nearest the power switch.

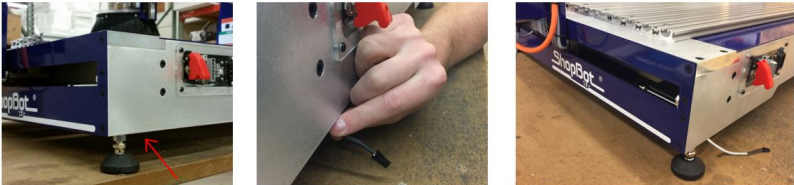

59

Plug the matching end of the interlock sensor cable into the wire on the tool.



# Enclosure Base Frame Assembly

61

These are the parts that you will need for this section.



62

Assemble **four** risers as shown by first connecting a foot spacer to a short foot using **4x** #10 x 1.25 Flange Head Screws; then attach a foot cup to the foot spacer using **4 more** screws.

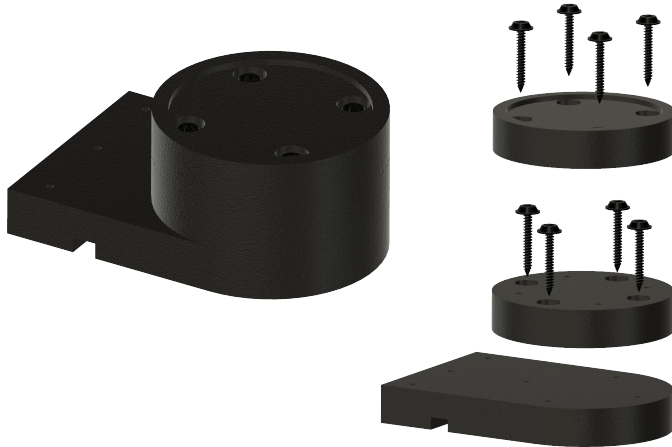

63

Now, with the assistance of another person, raise the enclosure frame up over the Desktop Max and lower it into place around the tool.

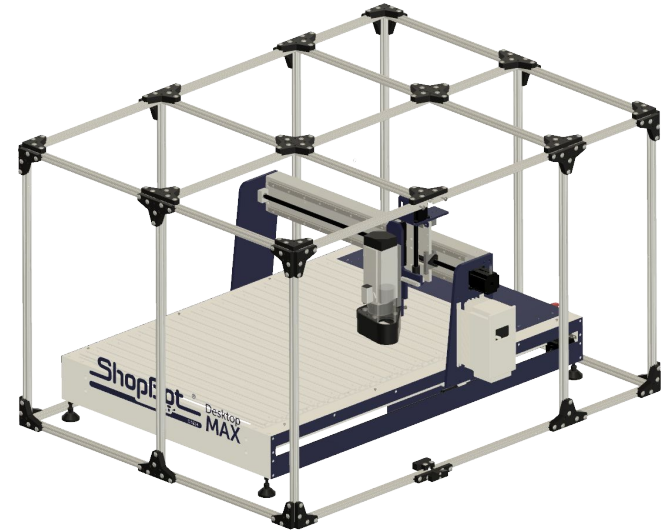

64

The risers assembled in the previous step will be placed under the rubber feet located at the corners of the tool frame. You'll need to tip the tool to one side and then the other to slide the risers into place under each of the feet.

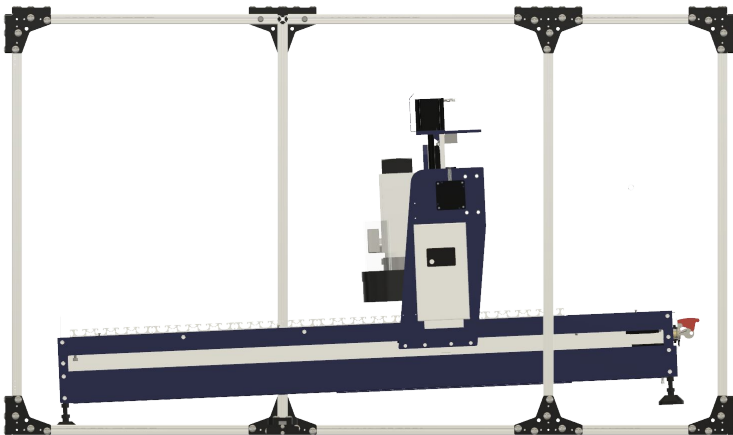

65

Start with the feet under the electronics enclosure. Slide risers under both feet and align the flat edge of the risers with the extrusion of the enclosure frame. Position the enclosure frame so that the plastic knob on the white VFD box will not collide with the enclosure frame when the tool is in motion.





66

Attach the riser to the enclosure frame using a plastic edge grip. Slide the edge grip into the extrusion slot, then secure it to the riser using 3 #10 x 1.25 Flange Head Screws. Then fasten the assembly to the extrusion using 3 #14 x 3/4 Truss Head Screws.

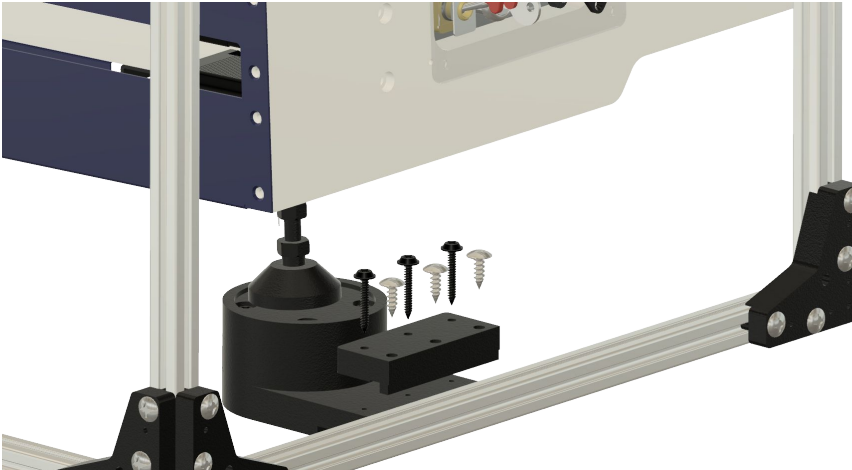

67

Do the same for the back foot.

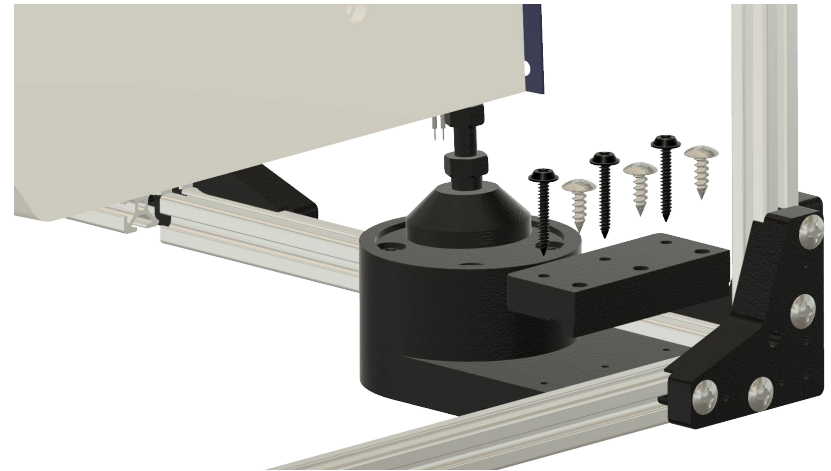

68

Next, lift the front edge of the tool and slide the two remaining risers into place under the front of the tool.



69

Attach the risers to the enclosure frame using edge grips.

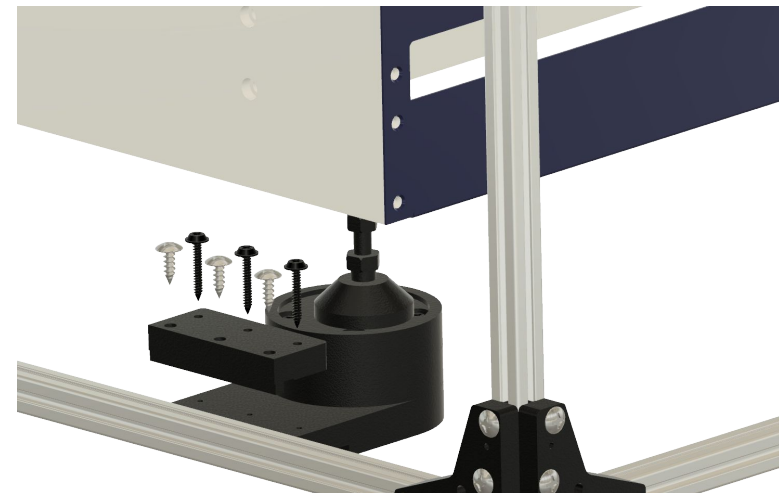

70

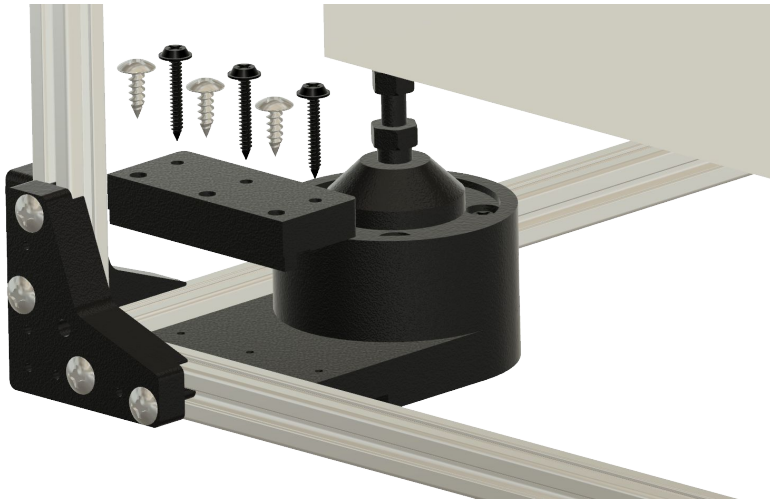

# ShopBot®

## Enclosure Door Installation

72

These are the parts that you will need for this section.



#14 x 3/4 Truss Head  
(006109) x6



#10 x 1.25  
Flange Head  
(005589) x8



#10 x 3/4"  
Flange Head  
(006129) x4



Door Assembly  
(006114) x2

73

This section will guide you through the installation of the doors for your enclosure.

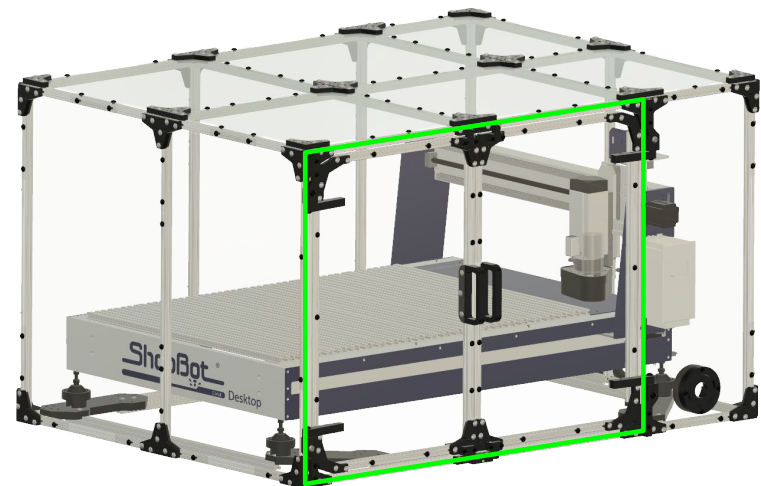



- 74 Every piece of joinery has additional small mounting holes. These will be used to mount the door hinges to your enclosure frame.

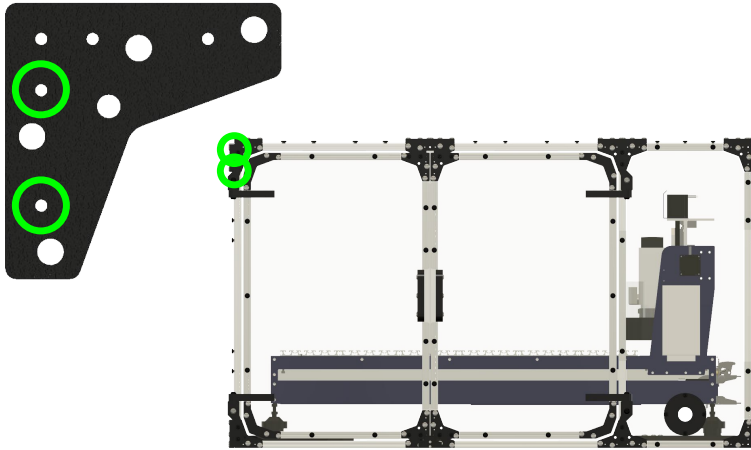

- 75 Remove the two doors from their packaging. Both doors are identical, there is no left or right.



- 76 Attach the Upper Hinge of the right door to the T Joint at the top edge of the enclosure.

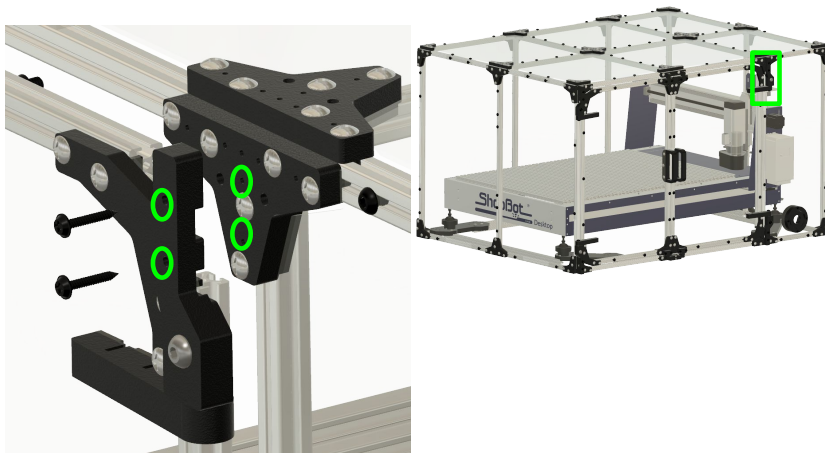

- 77 Attach the Lower Hinge of the right door to the T Joint at the base edge of the enclosure.



**78** Attach the Upper Hinge of the left door to the L Joint at the top corner of the enclosure.

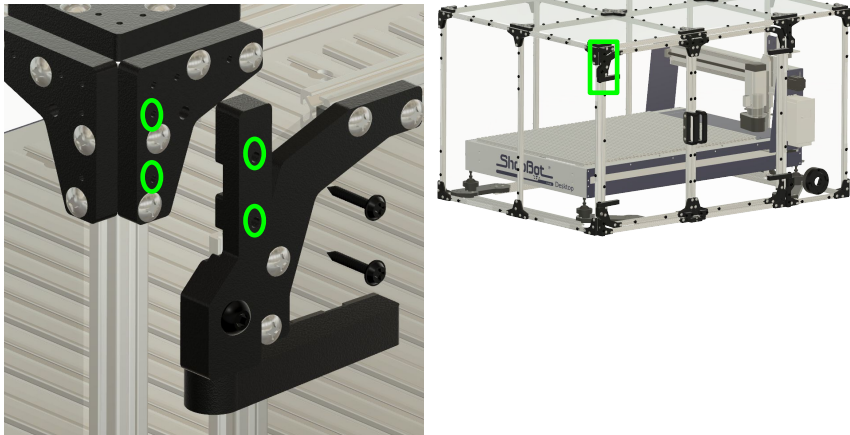

**79** Attach the Lower Hinge of the left door to the L Joint at the base corner of the enclosure.

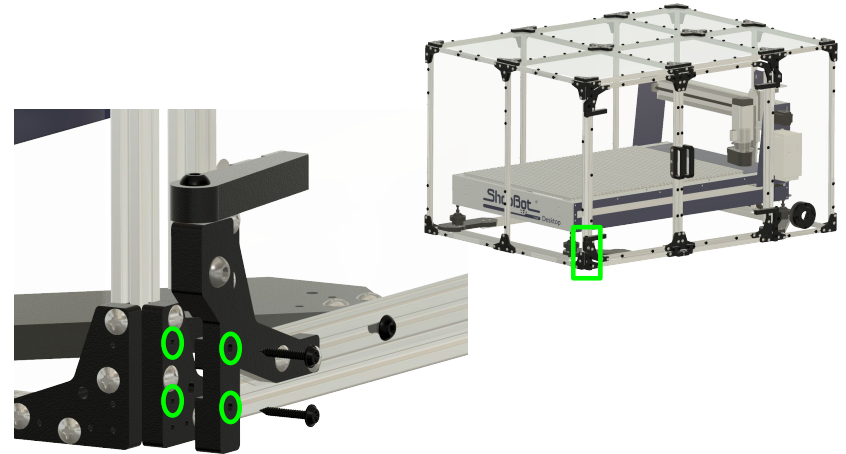

**80** Attach the handle to the right door by sliding it into the gap in the glass and securing it to the extrusion using three screws.

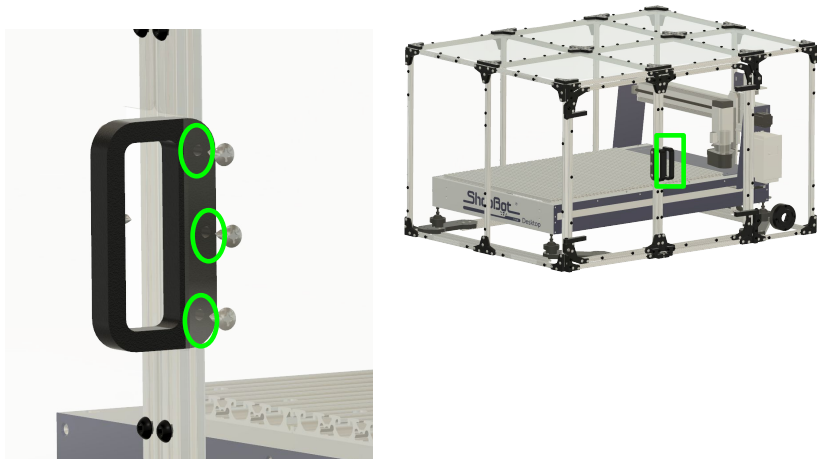

**81** Attach the handle to the left door by sliding it into the gap in the glass and securing it to the extrusion using three screws.

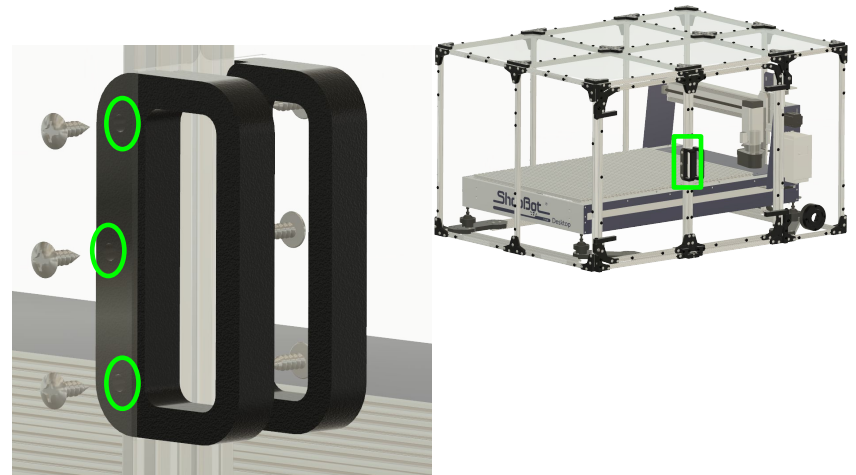

82

Insert #10 x 3/4" Flange Head Screws into the I Joints to act as catches for the magnets in the two latches attached to each door. This will hold the doors shut.

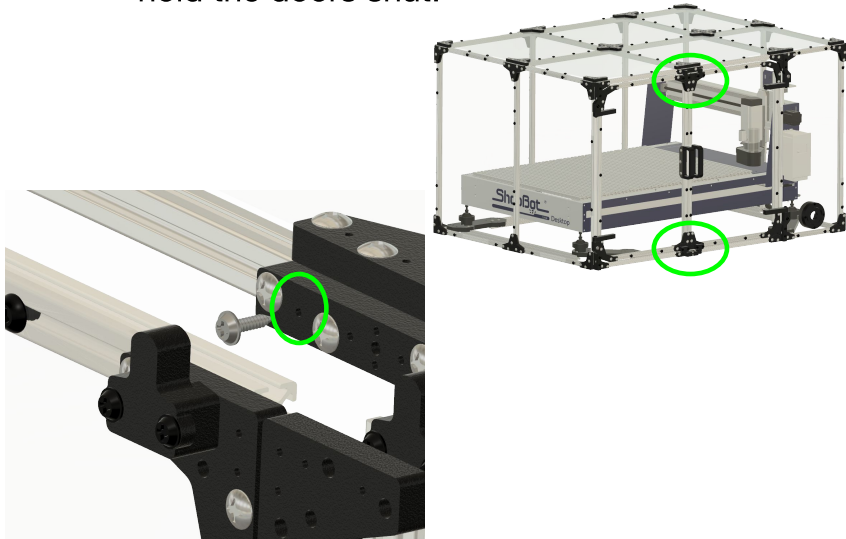

## Enclosure Window Installation

84

These are the parts that you will need for this section.



85

The windows for your enclosure are designed with an interlocking pattern so that multiple windows can be attached to a single piece of extrusion. If a window doesn't fit, try flipping or rotating it so that it keys with adjacent panels.

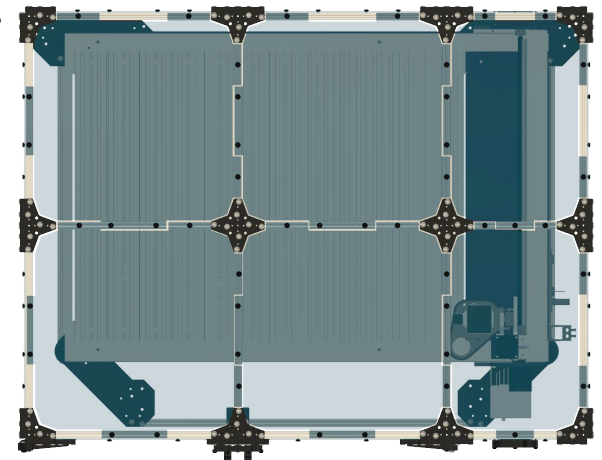

86

The mounting screws for the windows will thread into the V-Slot of the extrusion. These steps will be made much faster by inserting the driver bit in an electric driver or drill.

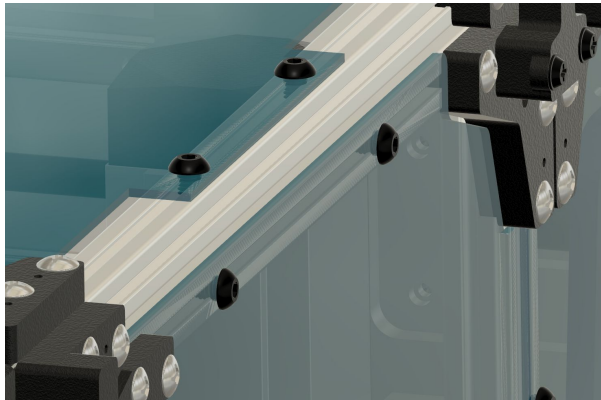

87

Attach **4x** Large Top Windows to the top side of the enclosure.

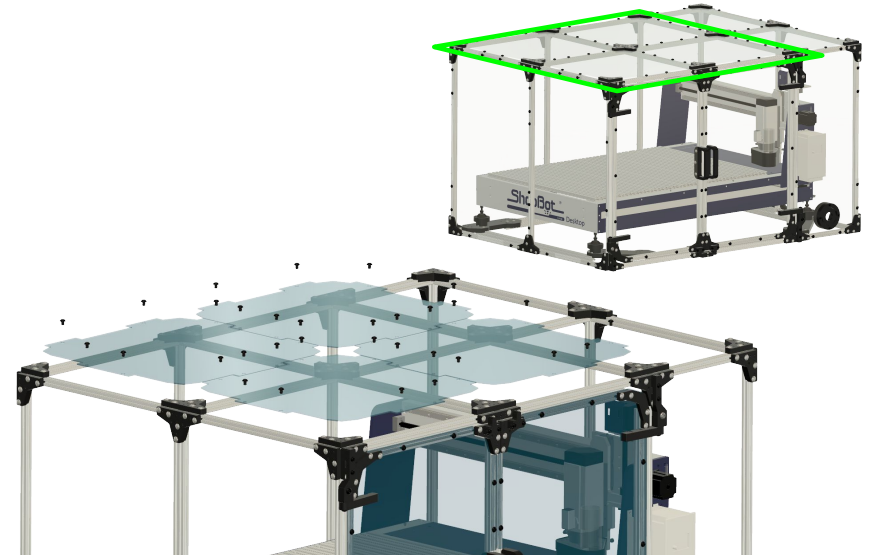

88

Attach **2x** Small Top Windows to the top side of the enclosure.

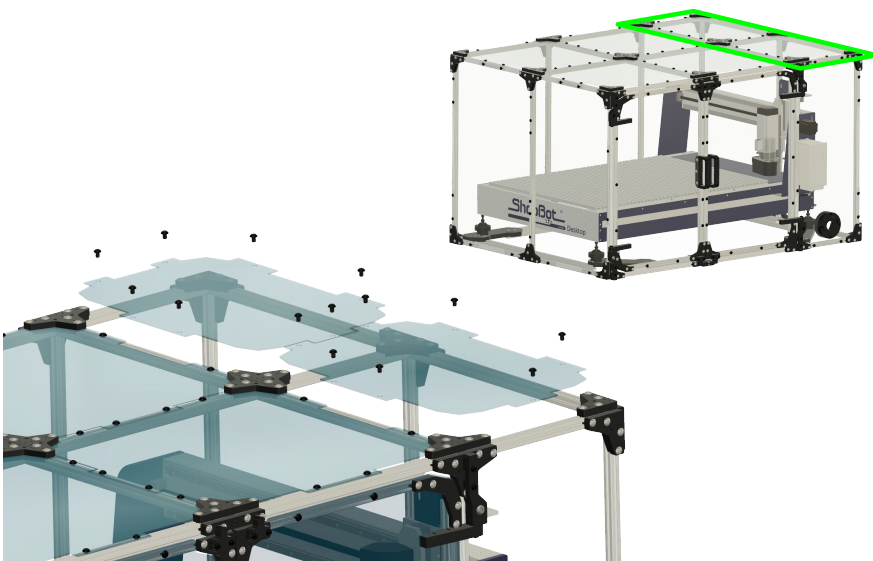

89

Attach **2x** Large Side Windows to the left side of the enclosure.

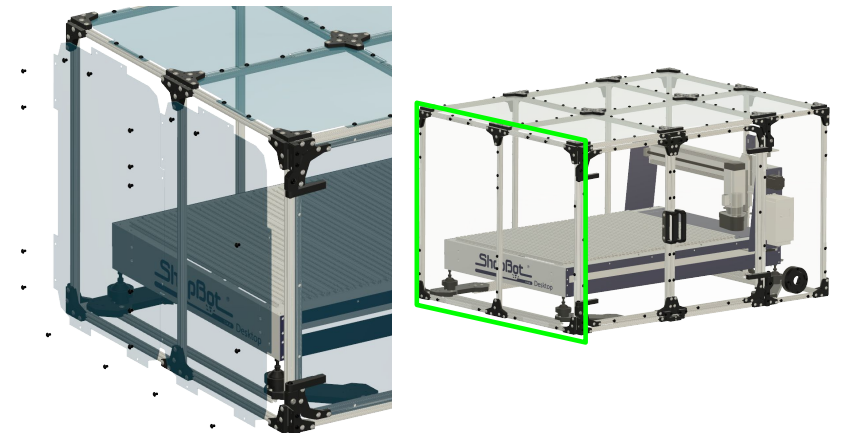



90

Attach **2x** Large Side Windows to the back side of the enclosure.

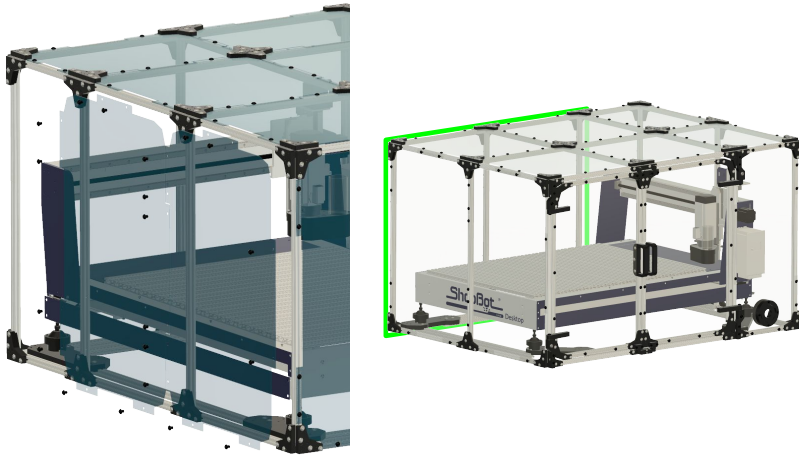

91

Note: The Side Narrow window that goes on the back side of the tool has an opening that can be used to pass the hose for a vacuum hold-down system into the enclosure. If you are not using a vacuum hold down system, you may want to cover this hole. To do so, use **4x** #10 x  $\frac{3}{4}$  Flange Head Screws and the vacuum cover piece (006009).

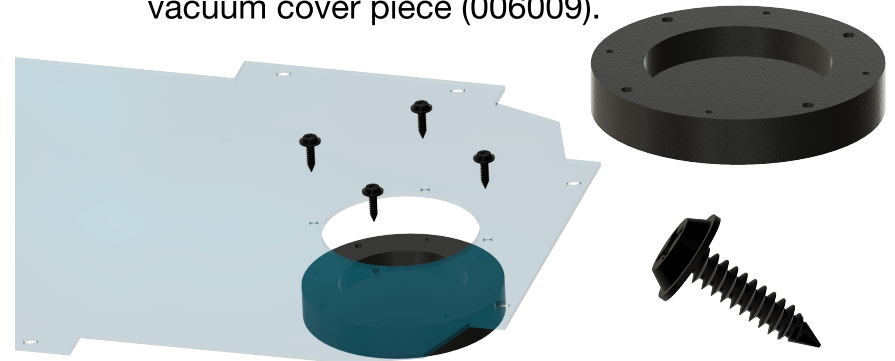

92

Attach a Narrow Side Window to the back side of the enclosure.

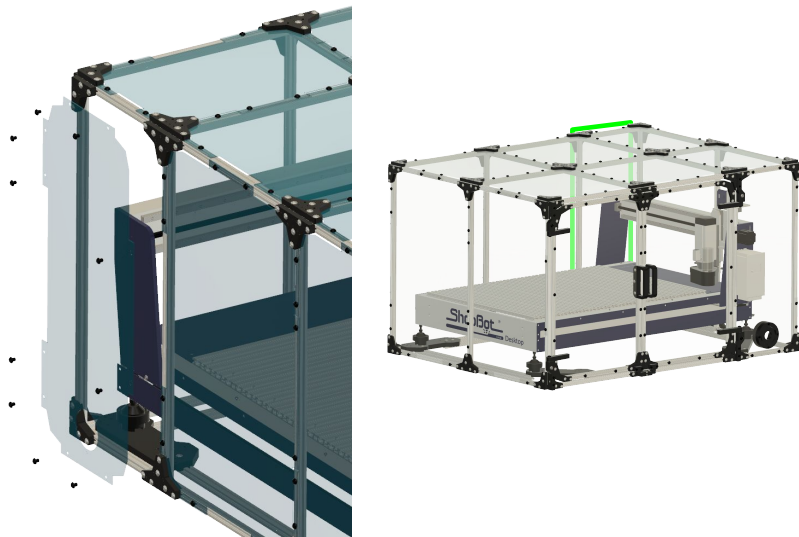

93

Attach a Large Side Window and a Large Window w/ Switch Acc. to the right side of the enclosure. Make sure that the opening in the switch acc. window is over the switch plate of the tool.

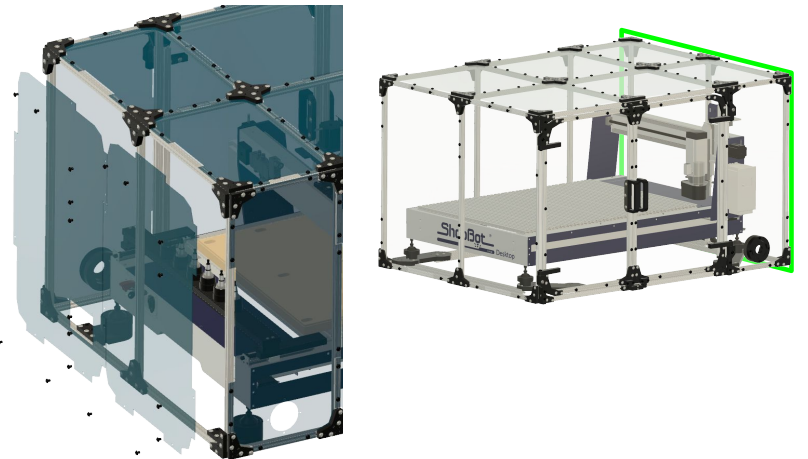

94 Attach a Narrow Side Window to the front right corner of the enclosure.

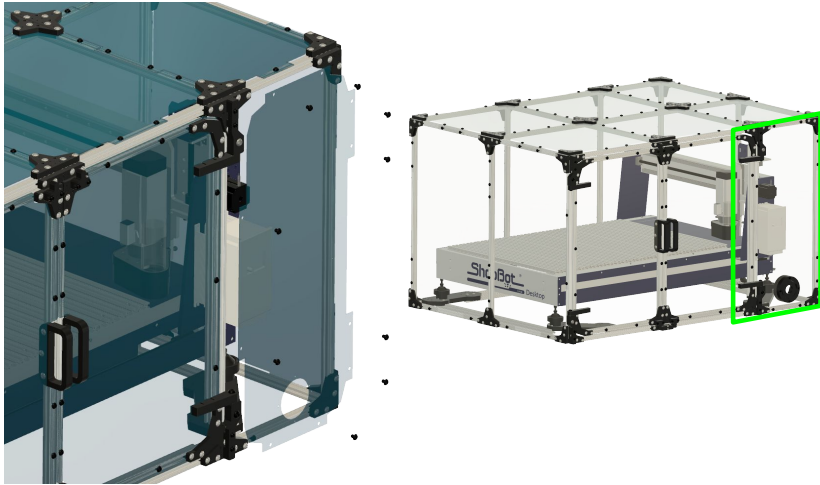

## Additional Features

96 Attach the Outer Vacuum Ring to the Inner Vacuum Ring through the openings in the Narrow Side Window on the right side of the enclosure using 4x #10 x 1.25 Flange Head Screws.

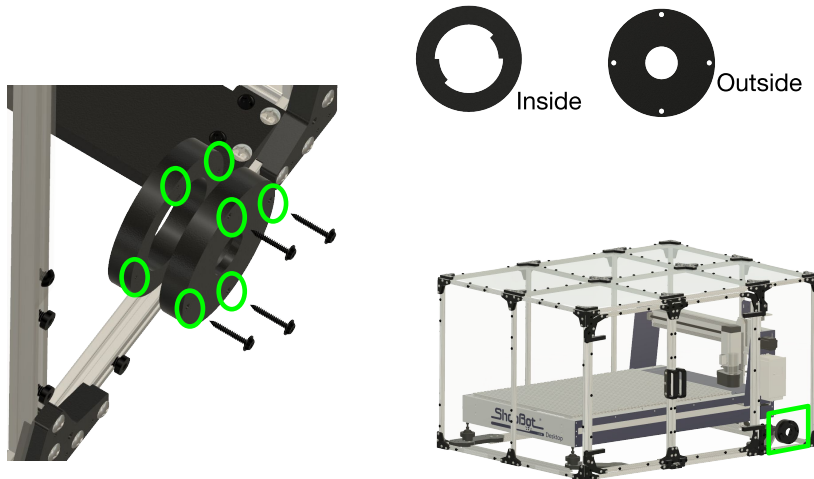

97 The Vacuum Tube supplied with your enclosure threads into the inside of the vacuum fitting -- twist counter-clockwise to lock in place.

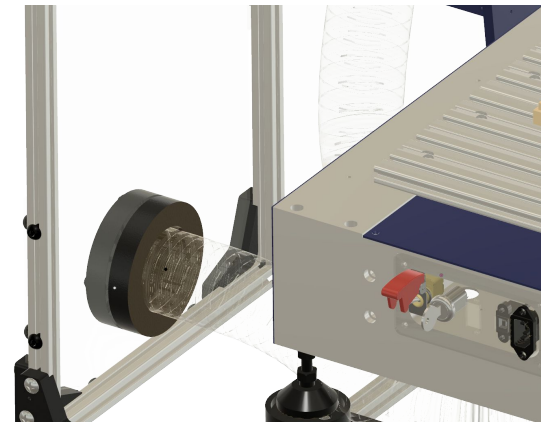

98

The Vacuum Tube will coil under the tool. Guide it upwards behind the VFD, along the gantry end plate.

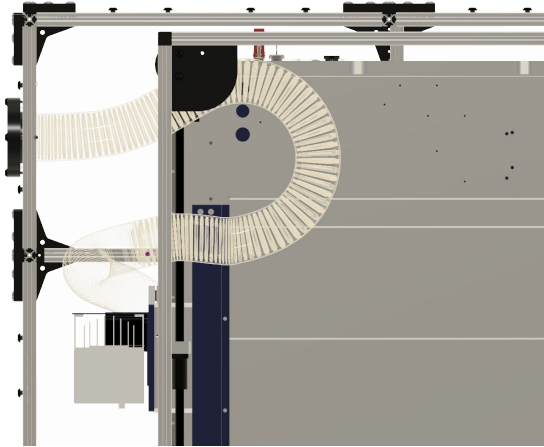

99

From here the tube can be routed across the gantry and inserted over the clear plastic tube on the dust foot assembly. Use the included zip ties to secure the hose in place by tying it to the wire bundle that climbs the gantry end plate behind the VFD.

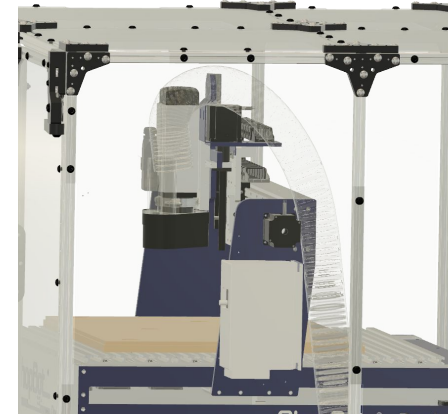

100

An extra riser foot is included with your enclosure. It can be flipped over and used as a bit holder inside your enclosure. Simply attach it where desired using an edge grip and screws.

