

PRT Spring Mount Upgrade

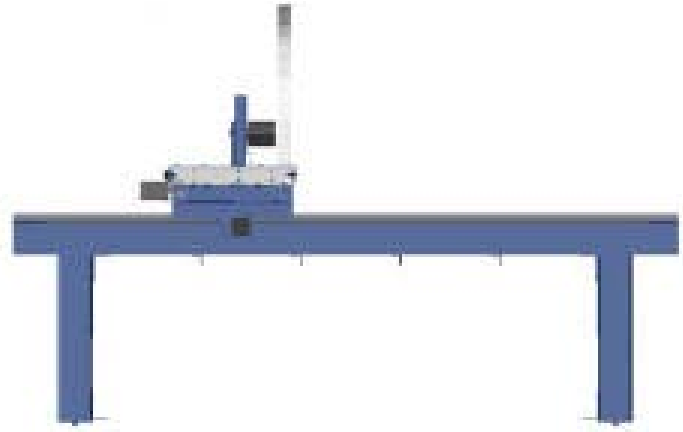
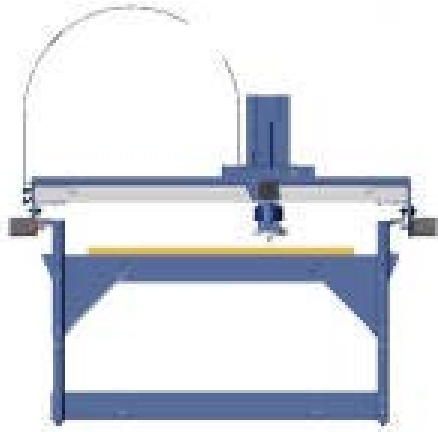

Table of Contents

Shopbot Contact Info.....	1
Parts Lists.....	2
Porter Cable Router Kit	2
3 HP Colombo and 4 HP HSD Kit	2
5 HP Colombo Kit	2
Installation Instructions.....	3
Step 1: Drill Mounting Bracket Holes	3
Step 2: Drill the Top Holes	3
Step 3: Mount the Spring Top.....	4
Step 4: Mount the Spring Bottom	4

Shopbot Contact Info

ShopBot Tools, Inc
 3333B Industrial Dr
 Durham, NC 27704
 919-680-4800 or 888-680-4466
www.shopbottools.com

Parts Lists

Porter Cable Router Kit



Qty	Part #	Description
2	000088	8 1/2" x 1/2" Springs
2	000533	3/8-16x1" Bolts
2	000092	3/8" Lock Washers
2	000453	3/8-16 Nuts
2	000525	1/4-20x2 1/2" Bolts
4	000849	1/4" Flat Washers
2	000454	1/4-20 Nylock Hex Nuts
1	000389	Spring Mount Bracket

3 HP Colombo and 4 HP HSD Kit



Qty	Part #	Description
1	000021	12" x 1" Springs
1	000088	8 1/2" x 1/2" Springs
2	000533	3/8-16x1" Bolts
2	000092	3/8" Lock Washers
2	000453	3/8-16 Nuts
2	000525	1/4-20x2 1/2" Bolts
4	000849	1/4" Flat Washers
2	000454	1/4-20 Nylock Hex Nuts
1	000389	Spring Mount Bracket

5 HP Colombo Kit



Qty	Part #	Description
2	000021	12" x 1" Springs
2	000533	3/8-16x1" Bolts
2	000092	3/8" Lock Washers
2	000453	3/8-16 Nuts
2	000525	1/4-20x2 1/2" Bolts
4	000849	1/4" Flat Washers
2	000454	1/4-20 Nylock Hex Nuts
1	000389	Spring Mount Bracket

Installation Instructions

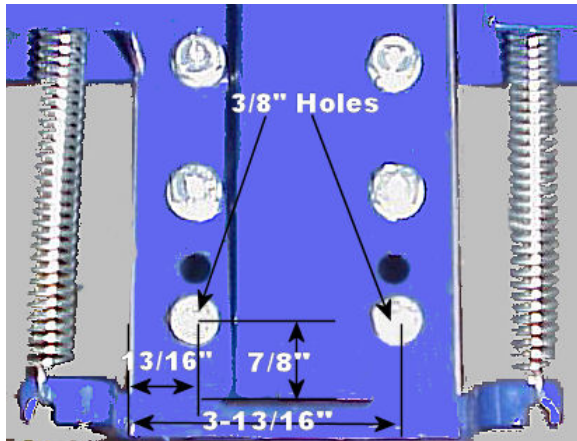

Step 1: Drill Mounting Bracket Holes

First, drill two 3/8" holes approximately 7/8" inches from the bottom, one 13/16" and one 3-13/16" from the left edge of your T frame as shown to the left.

Now, mount the extension spring mounting bracket with the 3/8" hardware.

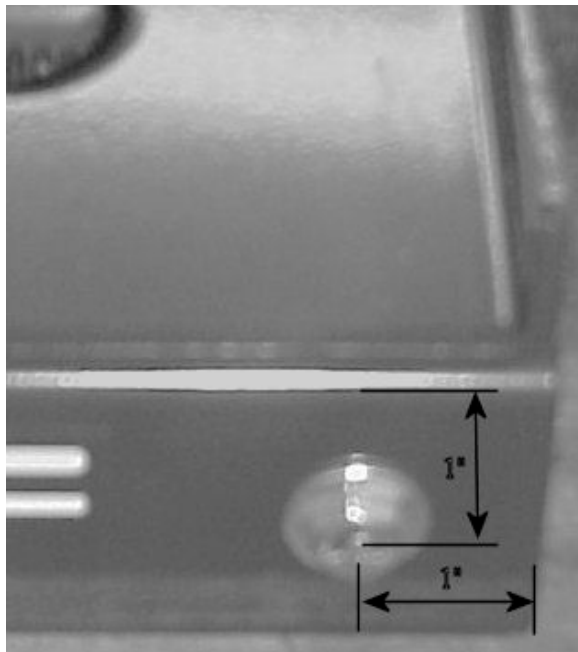

Step 2: Drill the Top Holes

You will need to drill two 1/4" holes 1" from the top and 1" from the side of the Z axis.

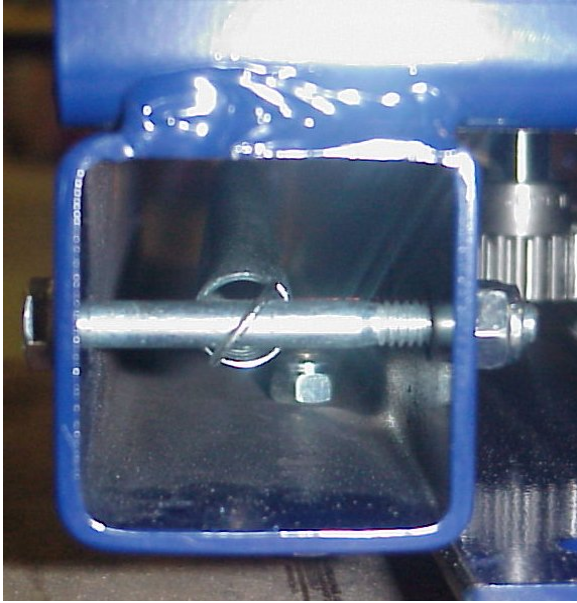

Step 3: Mount the Spring Top

Insert the 1/4" bolt about half way through the 1/4" holes drilled in the previous step.

Slide the bolt through the spring hook and the second hole and secure it with the washer and lock nut. (See Figure 4)

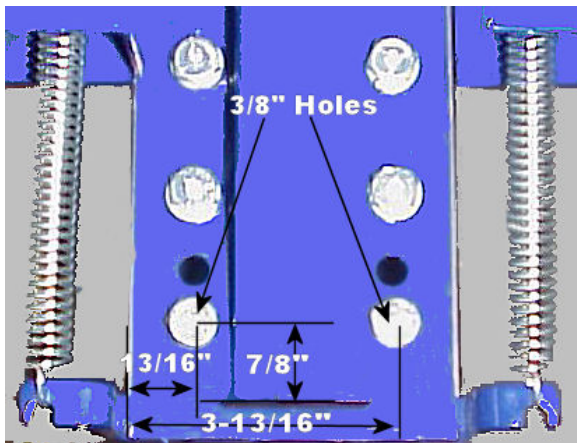

Step 4: Mount the Spring Bottom

Use a spring puller to guide and connect the spring to the spring mount.